

NEHRU COLLEGE OF ENGINEERING AND RESEARCH CENTRE

(Accredited by NAAC, Approved by AICTE New Delhi, Affiliated to APJKTU)

Pampady, Thiruvilwamala(PO), Thrissur(DT), Kerala 680 588

DEPARTMENT OF MECHANICAL ENGINEERING



LAB WORK BOOK



MECHANICAL WORKSHOP

VISION OF THE INSTITUTION

To mould our youngsters into Millennium Leaders not only in Technological and Scientific Fields but also to nurture and strengthen the innate goodness and human nature in them, to equip them to face the future challenges in technological breakthroughs and information explosions and deliver the bounties of frontier knowledge for the benefit of humankind in general and the down-trodden and underprivileged in particular as envisaged by our great Prime Minister Pandit Jawaharlal Nehru

MISSION OF THE INSTITUTION

To build a strong Centre of Excellence in Learning and Research in Engineering and Frontier Technology, to facilitate students to learn and imbibe discipline, culture and spirituality, besides encouraging them to assimilate the latest technological knowhow and to render a helping hand to the under privileged, thereby acquiring happiness and imparting the same to others without any reservation whatsoever and to facilitate the College to emerge into a magnificent and mighty launching pad to turn out technological giants, dedicated research scientists and intellectual leaders of the society who could prepare the country for a quantum jump in all fields of Science and Technology

ABOUT DEPARTMENT

- ◆ Established in: 2002
- ◆ Course offered: B.Tech in Mechanical Engineering
- ◆ Approved by AICTE New Delhi and Accredited by NAAC
- ◆ Affiliated to Dr. A P J Abdul Kalam Technological University.

DEPARTMENT VISION

Producing internationally competitive Mechanical Engineers with social responsibility & sustainable employability through viable strategies as well as competent exposure oriented quality education.

DEPARTMENT MISSION

1. Imparting high impacted education by providing conducive teaching learning environment.
2. Fostering effective modes of continuous learning process with moral & ethical values.
3. Enhancing leadership qualities with social commitment, professional attitude, unity, team spirit & communication skill.
4. Introducing the present scenario in research & development through collaborative efforts blended with industry & institution.

PROGRAMME EDUCATIONAL OBJECTIVES

- PEO1:** Graduates shall have strong practical & technical exposures in the field of Mechanical Engineering & will contribute to the society through innovation & enterprise.
- PEO2:** Graduates will have the demonstrated ability to analyze, formulate & solve design engineering / thermal engineering / materials & manufacturing / design issues & real life problems.
- PEO3:** Graduates will be capable of pursuing Mechanical Engineering profession with good communication skills, leadership qualities, team spirit & communication skills.
- PEO4:** Graduates will sustain an appetite for continuous learning by pursuing higher education & research in the allied areas of technology.

COURSE OUTCOME

CO 1	Identify Basic Mechanical workshop operations in accordance with the material and objects
CO 2	Apply appropriate Tools and Instruments with respect to the mechanical workshop trades
CO 3	Apply appropriate safety measures with respect to the mechanical workshop trades

CO VS PO'S AND PSO'S MAPPING

CO	PO1	PO2	PO3	PO4	PO5	PO6	PO7	PO8	PO9	PO10	PO11	PO12
CO 1	1	-	-	-	1	1	-	-	2	2	-	-
CO 2	1	-	-	-	1	1	-	2	2	2	1	1
CO 3	2	-	-	-	-	-	-	-		--	-	1

Note: H-Highly correlated=3, M-Medium correlated=2, L-Less correlated=1

PREPARATION FOR THE LABORATORY SESSION
GENERAL INSTRUCTIONS TO STUDENTS

1. Read carefully and understand the description of the experiment in the lab manual. You may go to the lab at an earlier date to look at the experimental facility and understand it better. Consult the appropriate references to be completely familiar with the concepts and hardware.
2. Make sure that your observation for previous week experiment is evaluated by the faculty member and you have transferred all the contents to your record before entering to the lab/workshop.
3. At the beginning of the class, if the faculty or the instructor finds that a student is not adequately prepared, they will be marked as absent and not be allowed to perform the experiment.
4. Bring necessary material needed (writing materials, graphs, calculators, etc.) to perform the required preliminary analysis. It is a good idea to do sample calculations and as much of the analysis as possible during the session. Faculty help will be available. Errors in the procedure may thus be easily detected and rectified.
5. Please actively participate in class and don't hesitate to ask questions. Please utilize the teaching assistants fully. To encourage you to be prepared and to read the lab manual before coming to the laboratory, unannounced questions may be asked at any time during the lab.
6. Carelessness in personal conduct or in handling equipment may result in serious injury to the individual or the equipment. Do not run near moving machinery/equipment. Always be on the alert for strange sounds. Guard against entangling clothes in moving parts of machinery.
7. Students must follow the proper dress code inside the laboratory. To protect clothing from dirt, wear a lab coat. Long hair should be tied back. Shoes covering the whole foot will have to be worn.
8. In performing the experiments, please proceed carefully to minimize any water spills, especially on the electric circuits and wire.
9. Maintain silence, order and discipline inside the lab. Don't use cell phones inside the laboratory.

10. Any injury no matter how small must be reported to the instructor immediately.

11. Check with faculty members one week before the experiment to make sure that you have the handout for that experiment and all the apparatus.

AFTER THE LABORATORY SESSION

1. Clean up your work area.
2. Check with the technician before you leave.
3. Make sure you understand what kind of report is to be prepared and due submission of record is next lab class.
4. Do sample calculations and some preliminary work to verify that the experiment was successful

MAKE-UPS AND LATE WORK

Students must participate in all laboratory exercises as scheduled. They must obtain permission from the faculty member for absence, which would be granted only under justifiable circumstances. In such an event, a student must make arrangements for a make-up laboratory, which will be scheduled when the time is available after completing one cycle. Late submission will be awarded less mark for record and internals and zero in worst cases.

LABORATORY POLICIES

1. Food, beverages & mobile phones are not allowed in the laboratory at any time.
2. Do not sit or place anything on instrument benches.
3. Organizing laboratory experiments requires the help of laboratory technicians and staff. Be punctual.

SAFETY PRECAUTIONS

1. Always wear tight clothes
2. Never walk barefooted inside the Work Shop. Prefer to use Rubber soled shoes; closed shoe is recommended
3. Never try to operate any machine unless you know how to operate it.
4. Never touch moving parts.
5. Do not use defective tools.
6. Do not touch any live wire
7. In case of fire, disconnect the electric supply.
8. Those who have long hair should take precaution by dressing them properly.
9. Tools which are not being used should always be kept at their respective places.
10. Never carry an open sharp tool in the pocket.
11. Do not cut work piece by holding it in hand.
12. Never work in a place where there is no sufficient light.
13. Always keep in mind the position of fire extinguishers and first aid box.
14. The job should be properly fitted in the vice.
15. Use always the right tool for the right job.
16. Don't use file or spanner as a hammer.
17. Always try to learn things sincerely from the instructors concerned.
18. Always keep your mind on the job.
19. Make sure that your work is not affecting the work of fellow students in the work shop.
20. Shop floor must be kept clean, free from scarp, oil and grease.

SYLLABUS

MECHANICAL WORKSHOP

LIST OF EXERCISES

(Minimum EIGHT units mandatory and FIVE models from Units 2 to 8 mandatory)

UNIT 1:- General : Introduction to workshop practice, Safety precautions, Shop floor ethics, Basic First Aid knowledge.

Study of mechanical tools, components and their applications: (a) Tools: screw drivers, spanners, Allen keys, cutting pliers etc and accessories (b) bearings, seals, O-rings, circlips, keys etc.

UNIT 2:- Carpentry : Understanding of carpentry tools

Minimum any one model

1. T-Lap joint
2. Cross lap joint
3. Dovetail joint
4. Mortise joints

UNIT 3:- Foundry : Understanding of foundry tools

Minimum any one model

1. Bench Molding
2. Floor Molding
3. Core making
4. Pattern making

UNIT 4: - Sheet Metal : Understanding of sheet metal working tools

Minimum any one model

1. Cylindrical shape
2. Conical shape
3. Prismatic shaped job from sheet metal

UNIT 5: - Fitting : Understanding of tools used for fitting

Minimum any one model

1. Square Joint
2. V- Joint
3. Male and female fitting

UNIT 6: - Plumbing : Understanding of plumbing tools, pipe joints

Any one exercise on joining of pipes making use of minimum three types of pipe joints

UNIT 7: - Smithy: Understanding of tools used for smithy.

Demonstrating the forge-ability of different materials (MS, Al, alloy steel and cast steels) in cold and hot states.

Observing the qualitative difference in the hardness of these materials

Minimum any one exercise on smithy

1. Square prism
2. Hexagonal headed bolt
3. Hexagonal prism
4. Octagonal prism

UNIT 8: -Welding: Understanding of welding equipments

Minimum any one welding practice

Making Joints using electric arc welding. bead formation in horizontal, vertical and over head positions

UNIT 9: - Assembly: Demonstration only

Disassembling and assembling of

1. Cylinder and piston assembly
2. Tail stock assembly
3. Bicycle
4. Pump or any other machine

UNIT 10: - Machines: Demonstration and applications of the following machines

Shaping and slotting machine; Milling machine; Grinding Machine; Lathe; Drilling Machine.

UNIT 11: - Modern manufacturing methods: Power tools, CNC machine tools, 3D printing, Glass cutting.

INDEX

EXP NO	EXPERIMENT NAME	PAGE NO	MARKS	SIGN
1	STUDY OF MECHANICAL TOOLS	10		
2	CARPENTRY SECTION	19		
3	FOUNDRY	26		
4	SHEET METAL OPERATION	32		
5	FITTING	39		
6	PLUMBING	45		
7	SMITHY	47		
8	WELDING	51		
9	MACHINE TOOLS	60		
10	CNC MACHINE TOOLS	70		

FINAL VERIFICATION BY THE FACULTY

TOTAL MARKS:

INTERNAL EXAMINER

EXTERNAL EXAMINER

EXPERIMENT – 1

MECHANICAL TOOLS

AIM

To familiarize the marking ,measuring ,cutting and holding tools

MARKING AND MEASURING TOOLS:

Try square:-

It is used for marking and testing the square ness of planed surfaces. It consists of a steel blade, fitted in a cast iron stock. It is also used for flatness. The size of a try square usedfor varies from 150 mm to 300 mm, according to the length of the blade. It is less accurate when compared to the try square used in fitting shop.

Marking gauge:-

It is a tool used to mark lines parallel to the edges of wooden pieces. It consists of a square wooden stem with a riding wooden stock on it. A marking pin, made of steel is fitted on the stem. A mortise gauge consists of two pins. In these it is possible to adjust the distance between the pins, to draw two parallel lines on the stock.

Compass and dividers:-

This is used for marking circles, arcs, laying out perpendicular lines on the planed surface of the wood.

has two pointed ends the bent end is used for marking lines where the straight end cannot reach.

Surface plate:

The surface plate is machined to fine limits and is used for testing the flatness of the work piece. It is also used for marking out small works and is more precise than the marking table. The surface plate is made of cast iron, hardened steel or granite stone. It is specified by length ' width ' height' and grade.

Angle plate:

The angle plate is made of cast iron. It has two surfaces, machined at right angle to each other. Plates and components, which are to be marked out, may be held against the upright

face of the angle plate, to facilitate the marking. Slots are provided on the angle plate to clamp the work in position.

Universal Scribing Block:

This is used for scribing lines for layout work and checking parallel surfaces. It may be noted that its spindle can be quickly adjusted to any angle, by an adjusting screw.

Scriber:

A scriber is a slender steel tool, used to scribe or mark lines on metal work pieces . It is made of hardened and tempered high carbon steel.

TRY-SQUARE:

It is used for checking the trueness of an object and also for making.

The blade of the try-square is made of hardened steel and the stock of cast iron or steel.

PUNCHES:

These are used for making indentations on the scribed lines, to make them visible clearly.

These are made of high carbon steel. A punch is specified by its length and diameter.

DOT PUNCH:

This is used to lightly indent along the layout lines, to locate centre of holes and to provide a small centre mark for divider point. etc .The angle of the punch is 60° .

CENTRE PUNCH:

It is used to mark the location of the holes to be drilled. This is similar to a dot punch .The angle of the punch is 90° .

CALIPERS:

They are indirect measuring tools used to measure or transfer linear dimensions. These are used with the help of a steel rule to check inside and outside measurements. These are made of case hardened mild steel or hardened and tempered low carbon steel. These are specified by the length of the legs.

VERNIER CALIPERS:

These are used for measuring outside as well as inside dimensions accurately . It may also be used as a depth gauge. It has two jaws. One jaw is formed at one end of its main scale and the other jaw is made part of a vernier scale. 49 main scale divisions are divided into 50 equal parts in the vernier scale. Hence, one division of vernier scale is $1/50$ mm less than 1mm.This gives a least count of .02mm.

Least count may be defined as the minimum dimension which can be measured by the device. For measuring the size of an object; it is held between its jaws and noting the main scale and vernier scale readings; the size can be determined.

Vernier caliper is generally made of nickel-chromium steel. Its size is specified by the maximum length that can be measured by it.

VERNIER HEIGHT GAUGE:

The vernier height gauge, clamped with a scribe. It is used for layout work. An off-set scribe is used when it is required to take measurements from the surface, on which the gauge is standing. The accuracy is same as vernier calipers. Its size is specified by the maximum height that can be measured by it. It is made of nickel-chromium steel.

VERNIER DEPTH GAUGE:

It is used for precision measurement of blind holes, slots, grooves, etc. The working principle of this instrument is the same as that of the vernier caliper. It is made of nickel-chromium steel. Its size is specified by the maximum depth that can be measured by it.



STEEL RULE

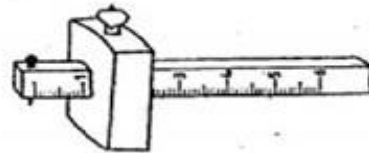

MARKING GAUGE

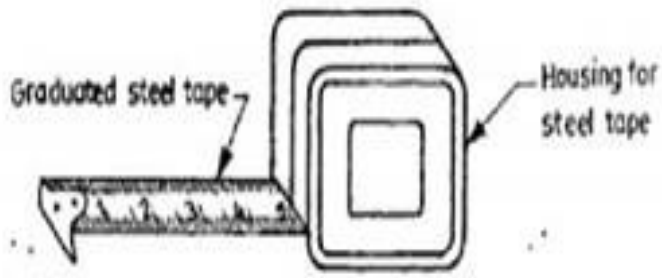

STEEL TAPE

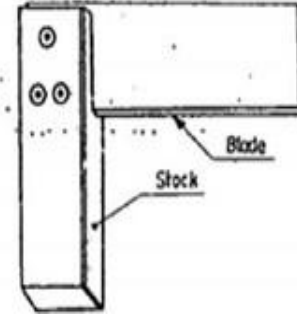

TRYSQAURE

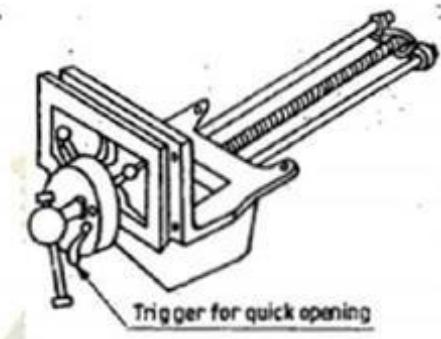

CARPENTER VICE

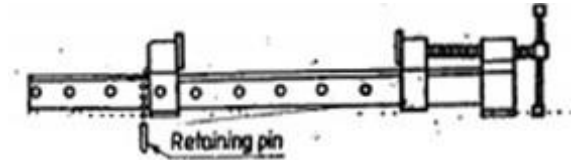

BARCLAMP

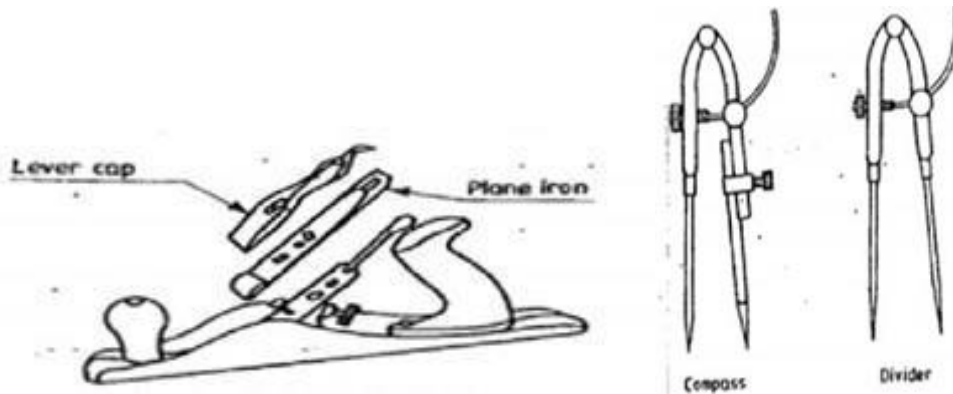

Metal jackplane

Compass and Divider

HOLDING AND CLAMPING TOOLS

BENCH VICE: The bench vice is a work-holding device. It is the most commonly used vice in a fitting shop. It is fixed to the bench with bolts and nuts. The vice body consists of two main parts, fixed jaw and a movable jaws. Jaws are made of hardened steel. The size of the vice is specified by the length of the jaws. The vice body is made of cast iron which is strong in compression.

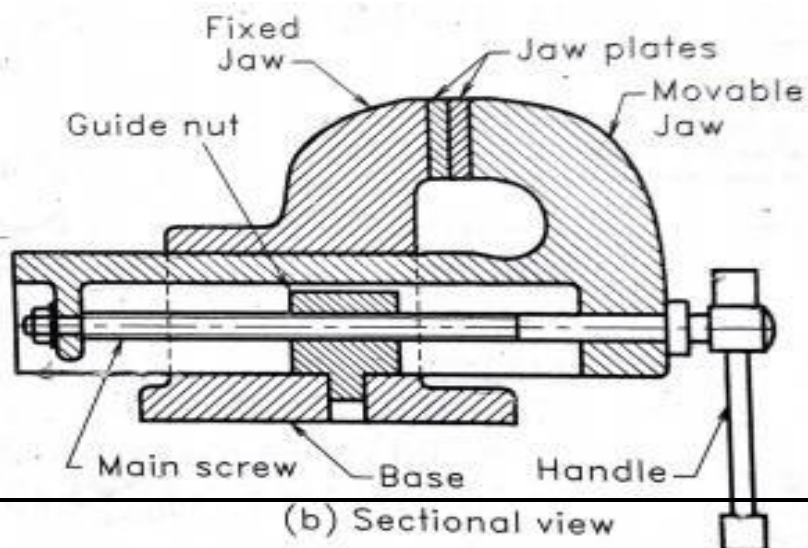

(b) Sectional view

V-BLOCK WITH CLAMP: The V-block is a rectangular or square block with a V-groove on one or both sides, opposite to each other. The angle of the 'V' is usually 90°. V-block with a clamp is used to hold cylindrical work securely.

CUTTING TOOLS

FILE: A file is a hardened piece of steel containing a percentage of carbon or tungsten. Fine teeth are cut on the surface of the teeth in slanting rows. Files are classified according to the following factors:

1. The cut.
2. The shape.
3. The length.

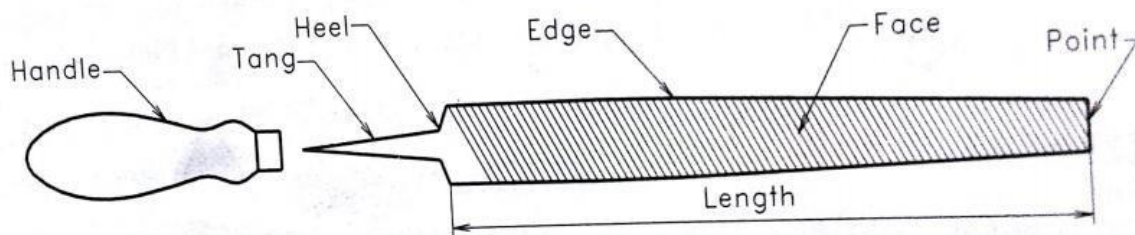

SINGLE CUT FILE: A single cut file will be having parallel teeth at 60 degree inclination to the centre line.

DOUBLE CUT FILE: double cut files have two times cut-teeth; one as 60 degree and the other cut is 80 degree.

FILE CARD: It is a metal brush, used for cleaning the files, to free them from filings, clogged in- between the teeth .

CHIPPING: Removing the metal with a chisel is called chipping and Is normally used where machining is not possible .While chipping, safety goggles must be put on, to protect eyes from the flying chips.

HACKSAW: The hacksaw is used for cutting metal by hand. It consists of a frame, which holds a thin blade, firmly in position. Hacksaw blade is specified by the number of teeth per centimeter. Hacksaw blades have a number of teeth ranging from 5 to 15 per centimeter (cm). Blades having lesser number of teeth per cm are used for cutting soft materials like aluminum, brass and bronze. Blades having larger number of teeth per centimeter are used for cutting hard materials like steel and cast iron.

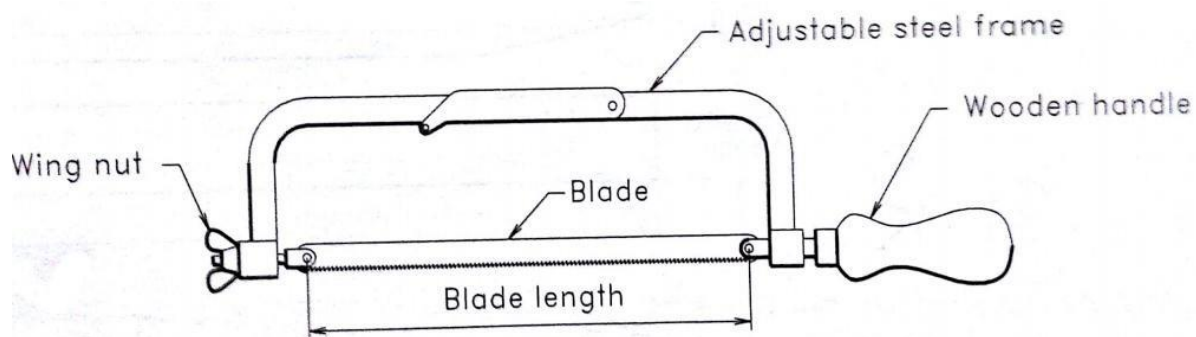

HACKSAW BLADES ARE CLASSIFIED AS: (i) All hard and (ii) flexible types. The all hard blades are made of H.S.S, hardened and tempered throughout to retain their cutting edges longer. These are used to cut hard metals. The size of the blade is measured by the distance between the pin holes.

CHISELS: Chisels are used for removing surplus metal or for cutting thin sheets. These tools are made from carbon steel of octagonal or hexagonal section. Chisels are annealed, hardened and tempered to produce a tough shank and a hard cutting edge. The cutting angle of the chisel for general purpose is about 60°.

TWIST DRILL: Twist drills are used for making holes. These are made of high speed steel. Both straight and taper shank twist drills are used. Cutting angle of the twist drill is 118° .

TAPS AND TAP WRENCHES: A tap is a hardened steel tool, used for cutting internal threads in a drilled hole. Hand taps are usually supplied in sets of three for each diameter and thread size. Each set consists of a taper tap, intermediate tap and plug or bottoming tap. Taps are made of high carbon steel or high speed steel.

1. First tap, or rougher - to start threading.
2. Second tap or intermediate - to cut the thread.
3. Bottoming tap or finisher - to finish the thread.

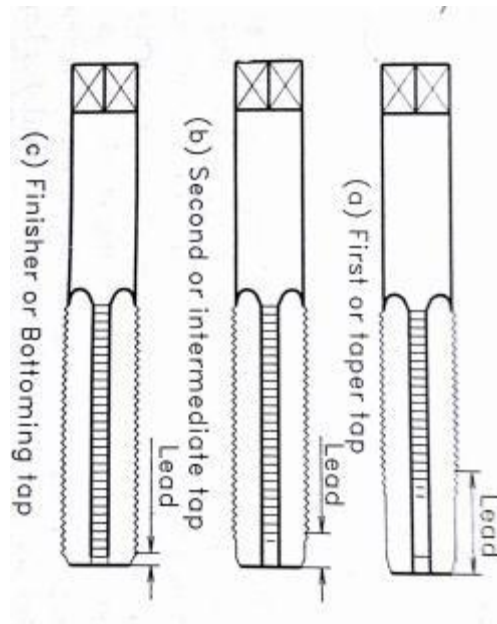

BENCH DRILLING MACHINE: Holes are drilled for fastening parts with rivets, bolts or for producing internal threads. Bench drilling machine is the most versatile machine used in a fitting shop for the purpose. Twist drills, made of tool or high speed steel are used with the drilling machine for drilling holes.

HAMMERS

Hammers are used to strike on a tool fastener or workpiece. They are made up of steel by forging process. Wooden or bamboo handle is fitted in the elliptical eye hole of the hammer.

BALL-PEEN HAMMER: Hammers are named, depending upon their shape and material and specified by their weight. A ball-peen hammer has a flat face, which is used for general work and a ball end, particularly used for riveting.

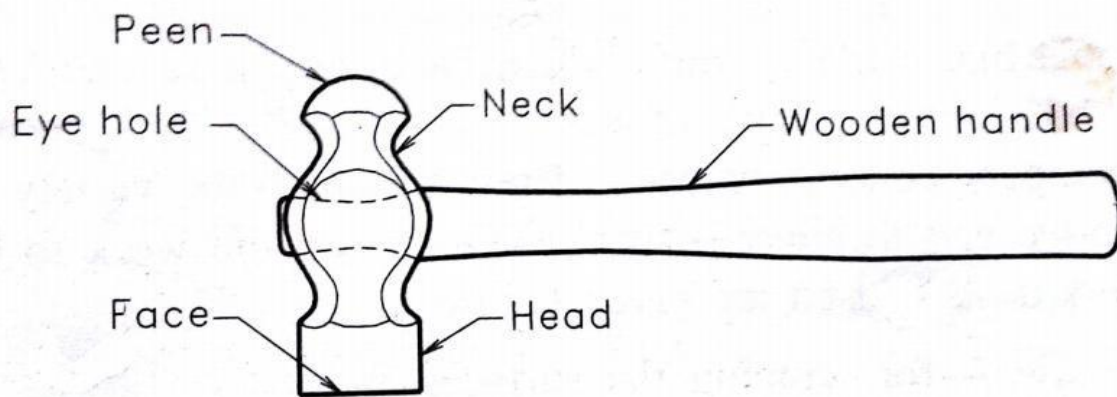

CROSS-PEEN HAMMER: It is similar to ball peen hammer, except the shape of the peen . This is used for chipping, riveting, bending and stretching metals and hammering inside the curves and shoulders.

STRAIGHT- PEEN HAMMER: This is similar to cross-peen hammer, but its peen is in-line with the hammer handle. It is used for swaging, riveting in restricted places and stretching metals.

SPANNERS: A spanner or wrench is a tool for gripping nuts and bolts. It is usually made of forged steel. There are many kinds of spanners. They are named according to the application. The size of the spanner denotes the size of the bolt on which it can work

EXPERIMENT 2

CARPENTRY SECTION

MODEL No. 1 PLANING PRACTICE

AIM:

Planing practice using the given wood piece.

MATERIALS REQUIRED:

Material: Hard wood (Mahagony) Size: 260x50x30 mm

TOOLS REQUIRED:

- 1-Steel rule
- 2-Try square,
- 3-Metal jack plane
- 4- Marking gauge
- 5-Carpentry Vice
- 6-Hand saw

LIST OF OPERATIONS:

1. Marking
2. Planing

PROCEDURE:

1. Copy the given drawing.
2. Collect the tools and wood piece.
3. Check the size of the wood piece for its suitability to make the model as per the drawing.
- 4 Plane one side of the wood piece using metal jack plane and check the straightness.
- 5 Plane the adjacent side of the wood piece and checked geometrical accuracy.
- 6 .Mark the thickness and width as per drawing using marking gauge.
7. Finish the planning operation and check the dimensions as per the drawing.

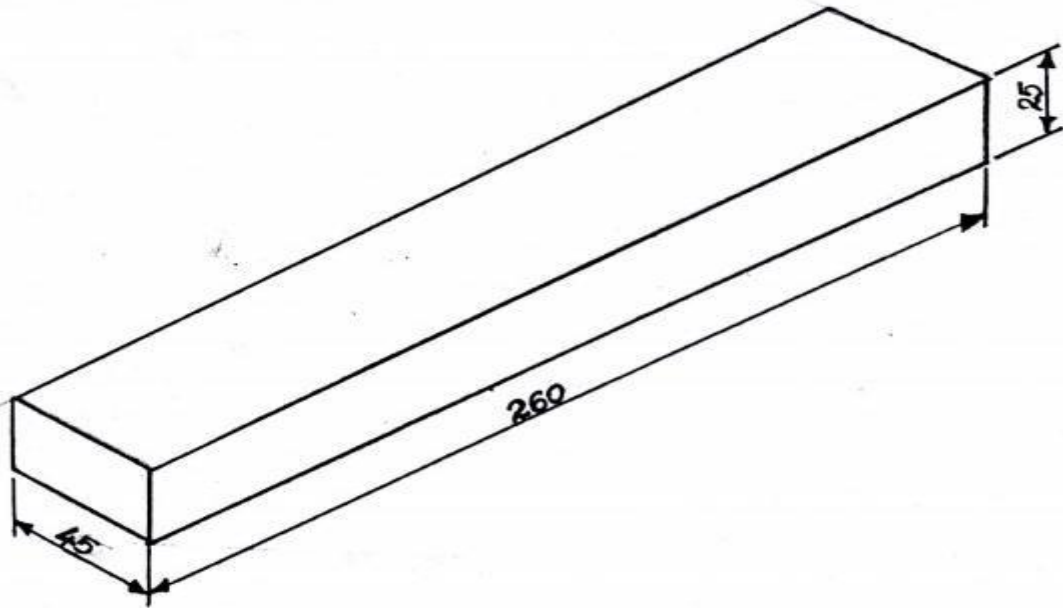

RESULT

INFERENCE

MODEL 2: T- LAP JOINT

AIM

To make T-Lap joint

TOOLS REQUIRED: -

1. Carpenter's vice
1. Steel Rule
2. Try square
3. Jack plane
4. Scriber
5. Cross cut saw
6. Marking gauge
7. Firmer chisel
8. Mallet
9. Wood rasp file and smooth file

MATERIAL REQUIRED: -

Wooden pieces of size 50 x 35 x 250 mm–2 Nos.

LIST OF OPERATIONS: -

1. Measuring and Marking
2. Planning
3. Check for squareness
4. Removal of extra material
5. Sawing
6. Chiseling
7. Finishing

PROCEDURE

1. The given reaper is checked for dimensions.
2. They are planed with jack plane and checked for straightness.
3. The two surfaces are checked for squareness with a try square.

4. Marking gauge is set and lines are marked at 30 and 45 mm to mark the thickness and width of the model respectively.
5. The excess material is first chiseled with firmer and then planned to correct size.
6. The mating dimensions of the parts X and Y are then marked using steel rule and marking gauge.
7. Using the crosscut saw, the portions to be removed are cut in both the pieces, followed by chiseling.
8. The ends of both the parts are chiseled to the exact lengths.
9. The fine finishing is given to the parts, if required so that, proper fitting is obtained.
10. The parts are fitted to obtain a slightly tight joint.

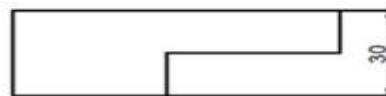
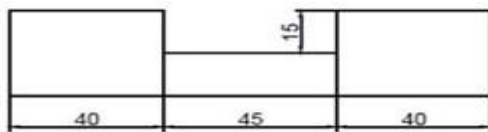

T-LAP JOINT

ALL DIMENSIONS ARE IN MM

RESULT

INFERENCE

MODEL NO. 3 DOVETAIL LAP JOINT

AIM

To make a Dovetail lap joint from the given reaper of size 50 x35 x250 mm.

TOOLS REQUIRED

1. Carpenter's vice
2. Steel Rule
3. Try square
4. Jack plane
5. Scriber
6. Cross cut saw
7. Marking gauge
8. Firmer chisel
9. Mortise chisel
10. Mallet
11. Wood rasp file and smooth file

MATERIAL REQUIRED

Wooden pieces of size 50 x 35 x 250 mm–2 Nos.

LIST OF OPERATIONS

1. Measuring and Marking
2. Planning
3. Check for square ness
4. Removal of extra material
5. Sawing
6. Chiseling

7. Finishing

Procedure: -

1. The given reaper is checked for dimensions.
2. They are planed with jack plane and checked for straightness.
3. The two surfaces are checked for square ness with a try square.
4. Marking gauge is set and lines are marked at 30 and 45 mm to mark the thickness and width of the model respectively.
5. The excess material is first chiseled with firmer chisel and then planned to correct size.
6. The mating dimensions of the parts X and Y are then marked using steel rule and marking gauge.
7. Using the crosscut saw, the portions to be removed are cut in both the pieces, followed by chiseling.
8. The ends of both the parts are chiseled to the exact lengths.
9. The fine finishing is given to the parts, if required so that, proper fitting is obtained.
10. The parts are fitted to obtain a slightly tight joint.

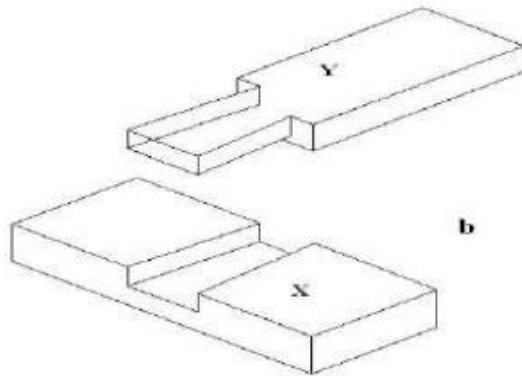
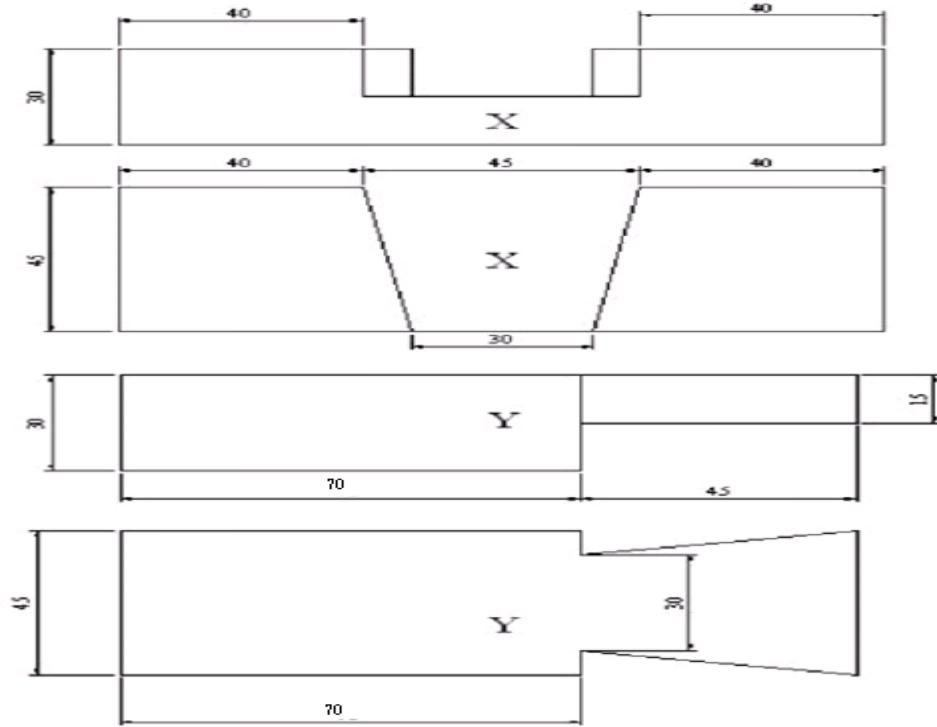

DOVETAIL LAP JOINT

EXPERIMENT- 3

FOUNDRY

Foundry practice deals with the process of making castings in moulds formed in either sand or some other material. The process involves the operations of pattern making, sand preparation, moulding melting of metals, pouring in moulds, cooling shake- out, fettling heat treatment, finishing and inspection. Moulding is the process of making moulds.

Moulds are classified as temporary and permanent. Temporary moulds are made of refractory and other binding materials and may be produced either through hand moulding or machine moulding.

MOULDING SAND: Sand is the principal material used in a foundry. The principal ingredients of moulding sands are: Silica sand, (ii) clay and (iii) moisture. Clay imparts the necessary bonding strength to the moulding sand. Moisture when added in correct proportion, provides the bonding action to the clay.

PROPERTIES OF MOULDING SAND: The essential requirement of a good moulding sand is that it should produce sound castings which are free from defects. For producing sound castings, moulding sand or mold should possess the following properties;

POROSITY OR PERMEABILITY: When molten metal is poured into a mould, gases and steam will be formed. The sand mould should have sufficient porosity to allow the gases and steam to pass through it. If they are not removed, casting defects such as blow holes will be formed.

PLASTICITY: It is the property of the moulding sand by virtue of which, it flows to all the corners around the pattern in the mold, when rammed. Only due to this property, the moulding sand gets the shape of the pattern in the mold.

COHESIVENESS: It is the property by which the sand particles stick to each other. Coarsegrained sand particles give better cohesiveness than spherical grained sand particles.

ADHESIVENESS: Sticking of the sand particles to another body is known as adhesiveness. The moulding sand sticks to the sides of the cope and drag parts of the moulding box.

PATTERNS: A pattern is the prototype of the desired casting, which when packed in a suitable material, produces a cavity called the mould. This cavity when filled with molten metal, produces the desired casting after solidification.

TYPES OF PATTERNS: Wood or metal patterns are used in foundry practice. Single piece, split, loose piece, multi-piece and cored patterns are some of the common types.

SINGLE PIECE PATTERN: It is the simplest of all the patterns. This has a flat surface on the cope side. This makes possible a straight line parting on the joint between the cope and drag of the mould. It is used for making simple castings.

SPLIT PATTERN: Split patterns are recommended for intricate castings, where removal of the pattern from the mould is difficult. The two halves of the pattern are put together by dowel pins.

LOOSE PIECE PATTERN: When a pattern cannot be withdrawn from the mould due to its complexity, loose pieces are provided to facilitate this. The loose parts or pieces are attached to the main body of the pattern with dowel pins. However, only two moulding boxes are required for making a mould in this case.

CORE BOX: A core box is a pattern, made of either wood or metal, into which sand is packed to form the core. Wood is commonly used for making a core box; but metal boxes are used when cores are to be made in large numbers. Specially prepared core sand is used in making cores.

PATTERN MATERIALS

The following are the materials that are widely used for making patterns:

1. Wood,
2. Metals and alloys,
3. Plastics,
4. Plasters and waxes.

MODEL NO. 1

BEARING

AIM:

To make a sand mould using the bearing pattern.

MATERIALS REQUIRED:

Moulding sand, parting sand water.

TOOLS REQUIRED:

Flask (cope & drag), Shovel, Hand rammer, Round rammer, Strike off -bar, Vent -wire, Trowel, Slick, Lifter, Sprue & Flow off pins (runner & riser), Hand riddle.

LIST OF OPERATIONS:

- 1- Preparation of moulding sand,
- 2- Compressing of sand over pattern, 3-Withdrawal of pattern,
- 4- Gate cutting,
- 5- Finishing of moulding surface.

PROCEDURE:

1. Copy the given drawing.
2. Collected the tools and materials.
3. Prepared the moulding sand and check the quality.
4. Placed the drag box keeping upside down and place the pattern.
5. Fill the sand, ram by hand rammer and remove excess sand by using strike -of bar.
6. Keep the drag box in normal position and finished the surface, also make air vent holes.
7. 7- Keep the top half of the pattern above the lower half and sprinkle parting sand.
- 8- Fix the cope box over the drag box and place the sprue pins and then fill the moulding sand.

9 - Remove excess sand, and make air vent holes.

10-Remove the sprue pins and detach the cope from drag.

11- Cut the gate on the drag box and withdraw the pattern. 12- Clean the mould cavity by lifters.

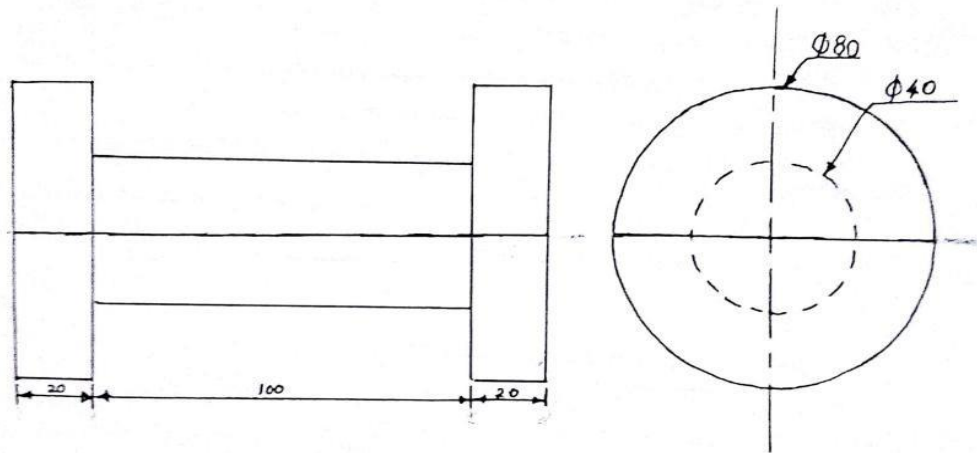

RESULT

INFERENCE

MODEL NO.2

DUMB BELL

AIM:

To make a sand mould using the bearing pattern.

MATERIALS REQUIRED:

Moulding sand, parting sand water.

TOOLS REQUIRED:

Flask (cope& drag), Shovel, Hand rammer, Round rammer, Strike off -bar, Vent -wire, Trowel,Slick,Lifter, Sprue & Flow off pins (runner& riser),Hand riddle.

LIST OF OPERATIONS:

- 1- Preparation of moulding sand,
- 2- Compressing of sand over pattern, 3-Withdrwal of pattern,
- 4- Gate cutting,
- 5- Finishing of moulding surface.

PROCEDURE:

- 1- Copy the given drawing.
- 2- Collected the tools and materials.
- 3- Prepared the moulding sand and check the quality.
- 4- Placed the drag box keeping upside down and place the pattern.
- 5- Fill the sand , ram by hand rammer and remove excess sand by using strike -of bar.
- 6- Keep the drag box in normal position and finished the surface, also make air vent holes.
- 7- Keep the top half of the pattern above the lower half and sprinkle parting sand.

8 - Fix the cope box over the drag box and place the sprue pins and then fill the moulding sand.

9 - Remove excess sand, and make air vent holes.

10- Remove the sprue pins and detach the cope from drag.

11- Cut the gate on the drag box and withdraw the pattern.

12- Clean the mould cavity by lifters.

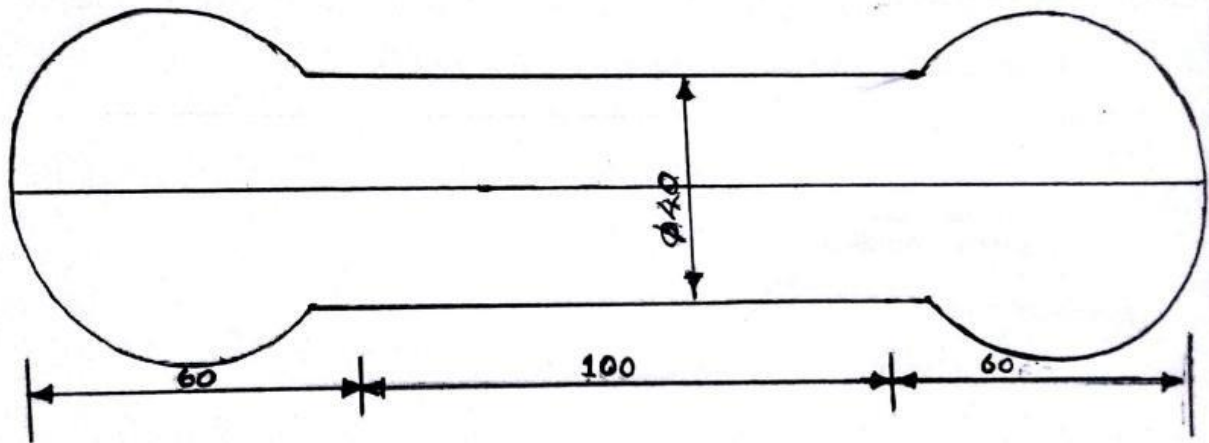

RESULT

INFERENCE

EXPERIMENT -4
SHEET METAL OPERATION

INTRODUCTION

Many engineering and house hold articles such as hoppers, guards, covers, boxes, cans, funnels, ducts, etc., are made from a flat sheet of metal; the process being known as tin smithy or sheet metal work. For this, the development of the article is first drawn on the sheet metal, then cut and folded, to form the required shape of the article.

SHEET METAL MATERIALS

A variety of metals are used in a sheet metal shop such as black iron, galvanized iron, copper, tin, aluminum and stainless steel.

A sheet of soft steel, which is coated with molten zinc, is known as galvanized iron. The zinc: coat forms a coating that resists rust, improves the appearance of the metal and permits it to be soldered with greater ease.

SHEET METAL JOINTS:

Various types of joints are used in sheet metal work, to suit the varying requirements. Some commonly used sheet metal joints and folded edges. These are self secured joints, formed by joining together two pieces of sheet metal and using the metal itself to form the joint. These joints are to be used on sheets of less than 1.6 mm thickness. Various forms of seams and hems are associated with sheet metal works; as described below:

A seam is a joint made by fastening two edges together. The following are the types of seams

SINGLE SEAM: It is used to join a bottom to a vertical body.

DOUBLE SEAM: It is similar to single seam, with the main difference that its formed edge is bent upward against the body. The layout process for this seam is similar to that used for a single seam.

GROOVED SEAM: It is made by hooking two folded edges together and then off- setting the seam. A hem is an edge made by folding. The following are the types of hems.

. **SINGLE HEM:** It is made by folding the edge of the sheet metal, to make it smooth and stiff.

DOUBLE HEM: It is a single hem, with its end bent.

WIRED EDGE: It consists of an edge which has been wrapped around a piece of wire. This edge is used where more strength is needed.

HAND GROOVER: It is used to flatten and shape joints made in sheet metal. The tool has a groove of required width and depth like a die. This groover is placed over the joint and hammered from the top to shape.

RIVETING: Rivets are used to fasten two or more sheets of metal together. It is the common practice to use rivets of the same material as that of the sheets being fastened. Tin men's rivets with flat heads are used on sheet metal work. For successful riveting operation, the selection of proper size and spacing of rivets is essential.

SOLDERING: Soldering is one method of joining two or more pieces of metals by means of fusible alloy, called solder, applied in the molten state-. The melting temperature of the solder should be lower than that of the base metals being joined. For a good job, the metals to be joined must be free from dirt, grease and oxide. Solder is made of tin and lead, usually in equal proportions. It comes either in the form of wire or bar. A soldered joint cannot withstand high temperatures (more than 150° C) and pressures.

SOLDERING IRON: Soldering requires a source of heat. A common method of transmitting heat to the metal surfaces is by using a soldering iron. The working end of this tool is made of copper, which is a good conductor of heat. In electrical soldering; the soldering iron is heated by passing current. But, in the ordinary soldering, the bit is heated by a heating source like furnace, etc

USES OF SOLDERING

Soldering is used to join the following:

1. Electrical components in television, radio, transistor and tape recorders
2. Electronic components like printed circuit boards
3. Automobile parts like radiators and copper pipes
4. Sheet metal works Utensil repairs

MODEL NO. 1

MARKING AND CUTTING PRACTICE

AIM:

To practice marking and cutting on a given sheet.

MATERIALS REQUIRED:

G.I sheet of size 110 X 110mm of 26swg

TOOLS REQUIRED:

1. Steel rule
2. Mallet
3. Scriber
4. Straight snips
5. Bench shear
6. Try square
7. Anvil

List of operations:

1. Laying out and marking
2. Cutting
3. Finishing

Procedure:

1. Copy the given drawing.
2. Collect the tools and sheet metal.
3. Draw the layout on the work material.
4. Cut the Sheet along the marked out line.

5. Check the edges of sheet for straightness and perpendicularity with the help of try square.
6. Mark the necessary lines to practice straight line cutting.
7. Cut the sheet along the marked lines using straight snips and straighten the sheet by the mallet.
8. Check the dimensions and finish the model

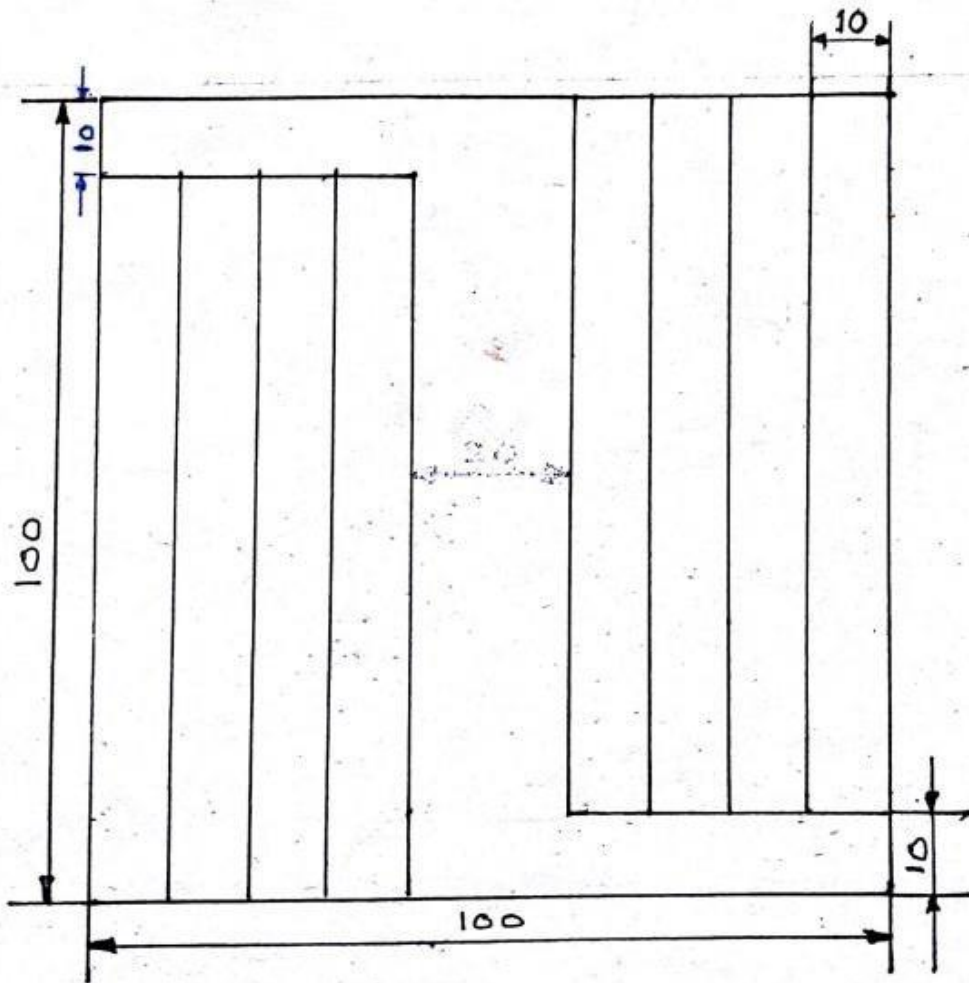

Scale 1:1 All dimensions are in mm

RESULT

INFERENCE

MODEL NO 2

AIM:

To make a square tray as per given dimensions.

MATERIALS REQUIRED:

G.I sheet of size 150 X 150mm of 26 swg.

TOOLS REQUIRED

1. Steel rule
2. Mallet
3. Scriber
4. Straight snips
5. Bench shear
6. Try square
7. Anvil

LIST OF OPERATIONS

1. Laying out and marking
2. Cutting, Notch cutting
3. Bending, Hemming
4. Finishing

PROCEDURE

1. Copy the given drawing.
2. Collect the tools and sheet metal.
3. Draw the layout on the work material.
4. Cut the Sheet along the marked out line.

5. Check the edges of sheet for straightness and perpendicularity with the help of try square.
6. Mark all the necessary line to make the required model.
7. Cut the sheet along the lines with straight snips.
8. Do all the bending operations to get the square as vertical sides.
9. Bent all edges to avoid sharp corners and edges for safety.
10. Straighten the four sides and then finish the model.
11. Check all the dimensions and finish.

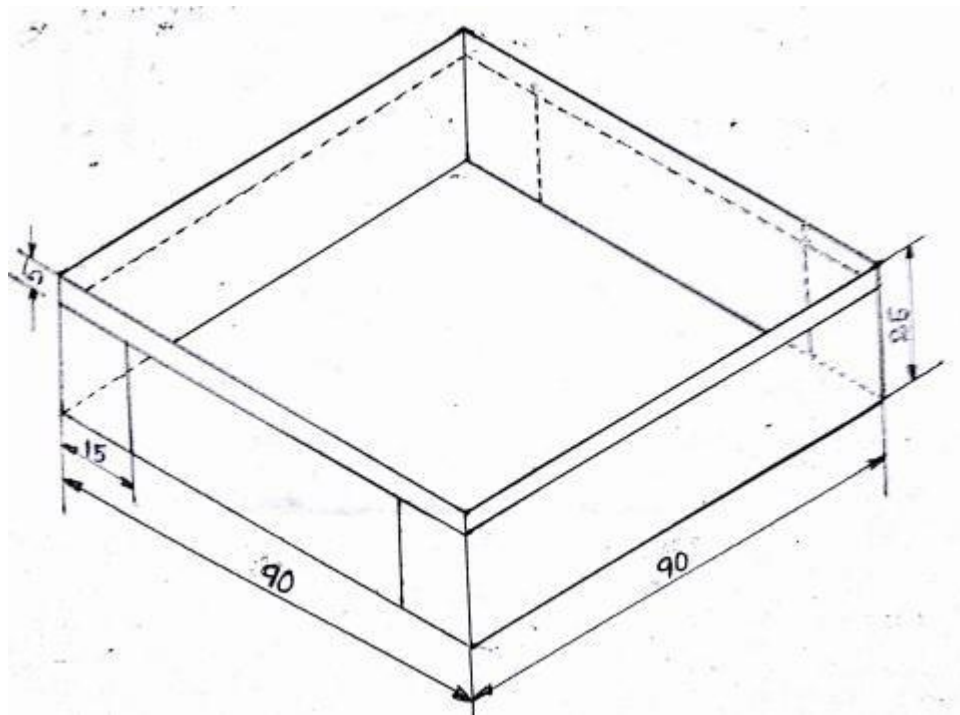

DEVELOPMENT OF TRAY

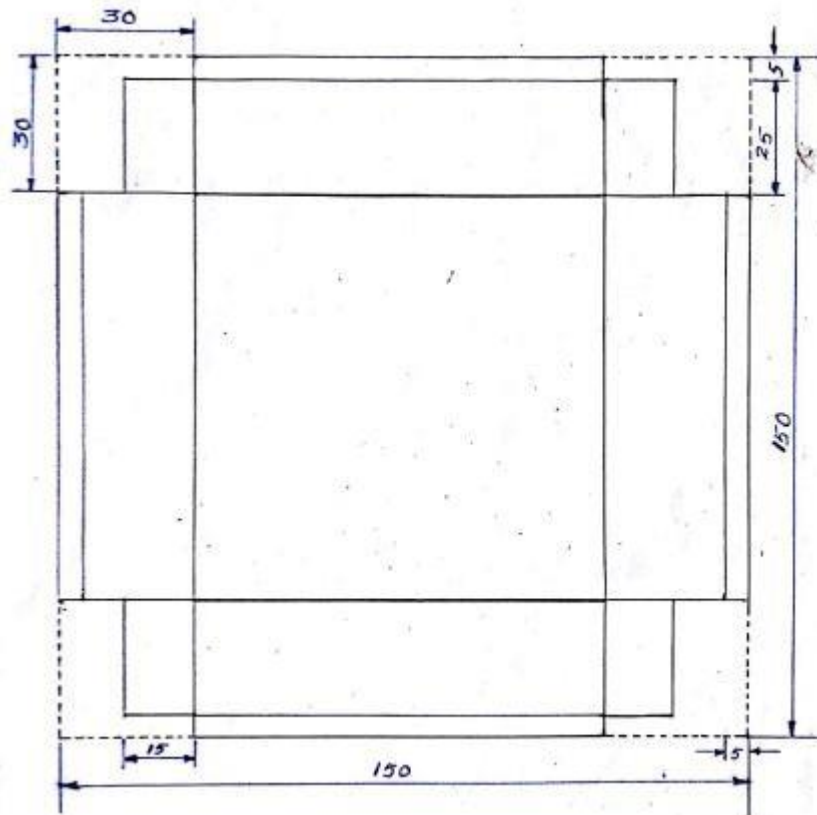

SCALE 1:1, All dimensions are in mm

RESULT

INFERENCE

EXPERIMENT 5

FITTING

INTRODUCTION

The term, "Bench work" refers to the production of components by hand on the bench, whereas fitting deals with the assembly of mating parts, through removal of metal, to obtain the required fit.

Both the bench work and fitting requires the use of number of simple hand tools and considerable manual effort. The operations in the above works consist of filing, chipping, scraping, sawing, drilling, tapping, etc.

MODEL NO: 1

FILING PRACTICE

AIM:

To make square of 45 x 45mm using the given mild steel flat piece by filing.

MATERIALS REQUIRED:

Mild steel flat of 50 x 50 x 6mm

TOOLS REQUIRED:

- Steel rule
- Scriber
- Centre punch
- Surface plate
- Vernier height gauge
- Flat file
- Try square

LIST OF OPERATIONS:

- laying out and marking

- punching
- cutting
- rough filing
- smooth filing

PROCEDURE:

1. Copy the given drawing.
2. Collect the tools and work piece.
3. Mark the layout on the work piece then punch the required lines.
4. Cut unwanted material from the work piece.
5. Filed the work piece as per the drawing.
6. Check all the dimensions and then finish the model.

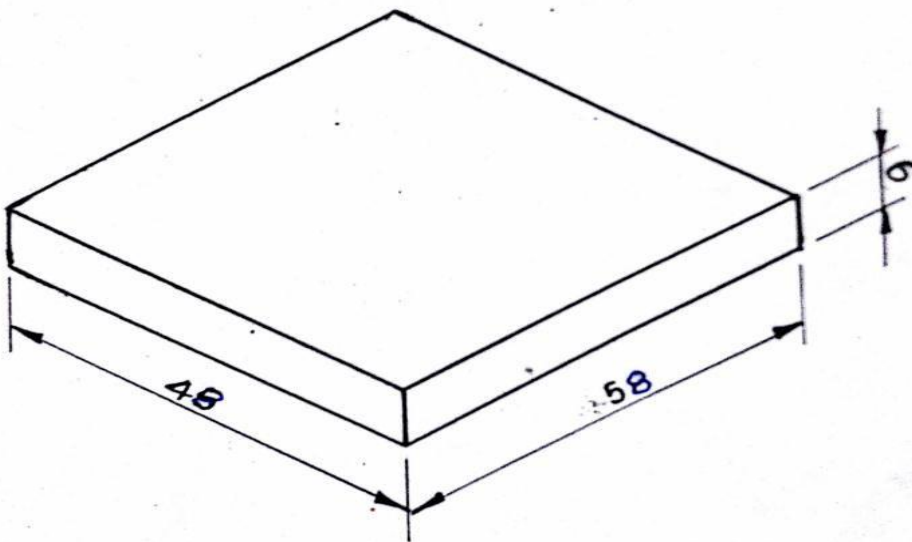

RESULT

INFERENCE

MODEL NO : 2

V-GROOVE

AIM:

To make a V-Groove on a given m.s flat as in the dimensions shown in fig.

MATERIALS REQUIRED :

Mild steel flat of 50 X 50X 6mm.

TOOLS REQUIRED:

- Steel rule
- Scriber
- Centre punch
- Surface plate
- Vernier height gauge
- Hack saw
- Flat file
- Try square

LIST OF OPERATIONS :

- Laying out and marking
- Punching
- Cutting
- Rough filing
- Smooth filing

PROCEDURE :

1. Copy the given drawing.
2. Collect the tools and work piece.
3. Mark the layout on the work piece then punch the required lines.

4. Cut unwanted material from the work piece.
5. After completing the square cut the V-groove .
6. Filed the V-Groove to the exact angle.
7. Check the angles of 'V' and finish the model.

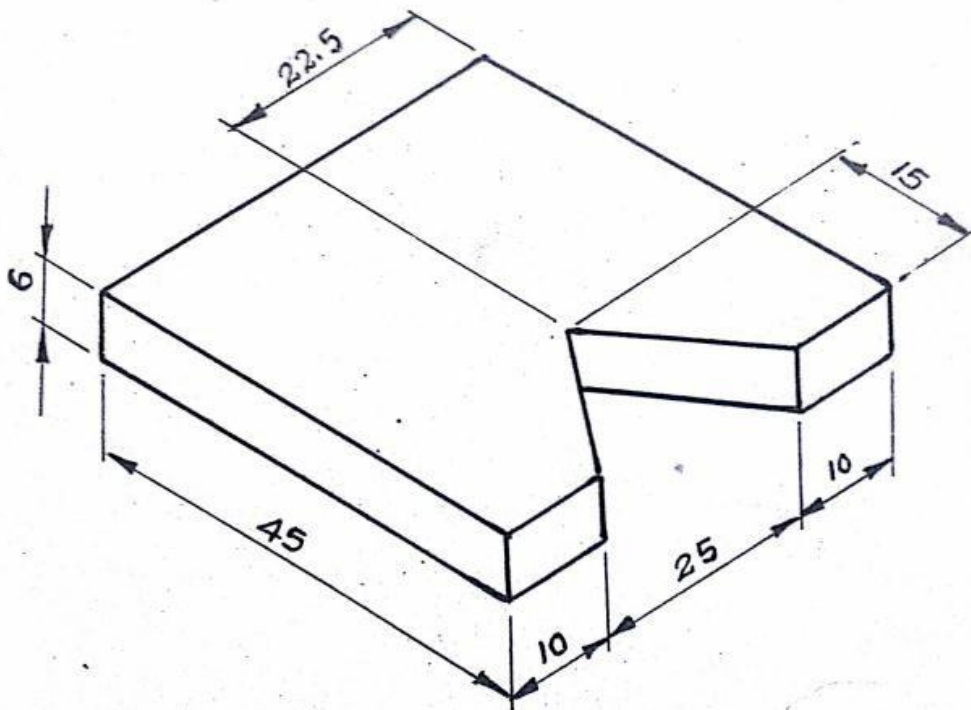

RESULT

INFERENCE

MODEL NO 3

VJOINT

AIM:

To make a v joint as per the given dimension shown in fig.

MATERIALS REQUIRED:

Mild steel flat of 50X50X6mm and 30x50X6mm

TOOLS REQUIRED:

- Steel rule.
- Scriber.
- Centre punch.
- Surface plate..
- Vernier height gauge.
- Hack saw.
- Flat file.
- Try square.

LIST OF OPERATIONS:

- Laying out and marking.
- Punching.
- Cutting.
- Rough filing.
- Smooth filing.

PROCEDURE:

- 1 Copy the given drawing.
- 2 Collect the tools and work piece.

- 3 Mark the layout on the work piece then punch the required lines.
- 4 Complete the cutting operation of two pieces.
5. Filed the two pieces together to form the joint.
6. Check the joints for dimensional accuracy.

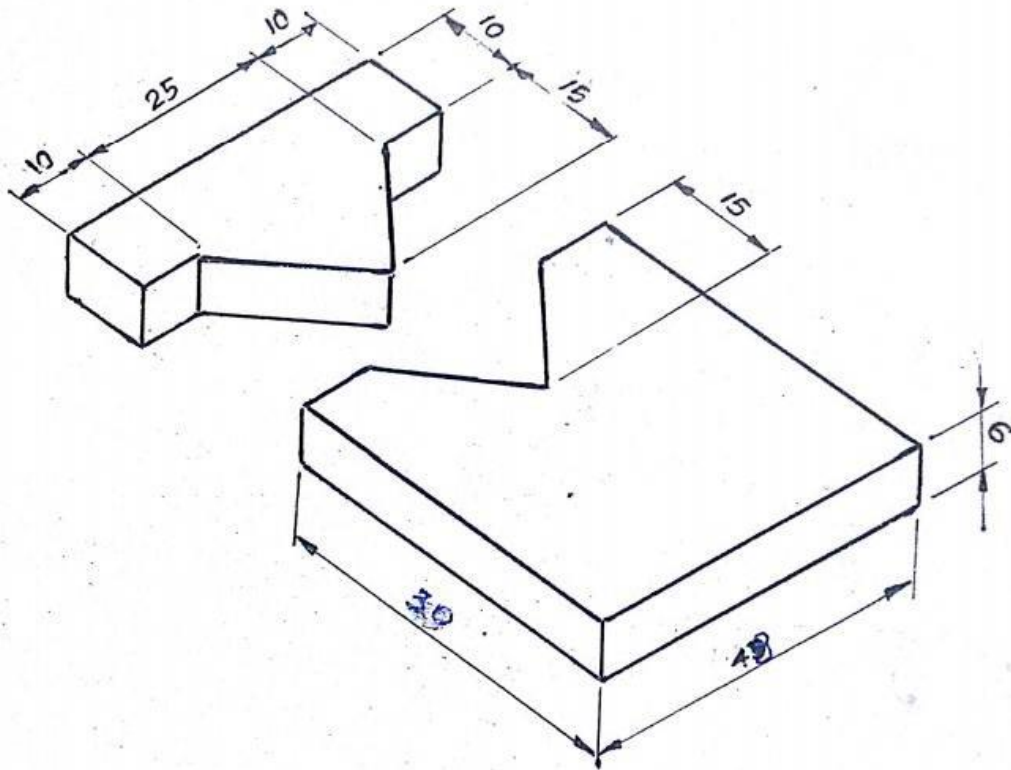

SCALE 1:1 All dimensions are in mm

RESULT

INFERENCE

EXPERIMENT -6

PLUMBING

Introduction

Plumbing refers to installation of pipelines, water tanks and other pipe fittings to distribute water in a building. PVC (Poly Vinyl Chloride) pipes and GI (Galvanized Iron) pipes are commonly used in plumbing.

Plumbing Tools Plumbing tools are many. The following tools are commonly used to install 25mm size pipelines.

Pipe wrench

A pipe wrench is used to hold and rotate the pipes to tight them. It consists of a fixed jaw, a movable jaw with adjusting screw.

Pipe vice A pipe vice is used to hold the pipe during cutting, making threads at the ends of the pipe, fitting of couplings, etc. It also consists of a fixed jaw, a movable jaw and a screw with handle for adjustment. Pipe

Fittings

A PVC pipe connection uses fitting like elbow, bend, coupling, tee reducer, etc. Fitting like couplings, elbow, bend, union, nipple, tee reducer, plug, cap, flange, etc. with V-threads are commonly used in GI pipe connections.

Valves and Taps

A gate valve or globe valve is commonly used in the main pipeline to control/regulate the flow of water through it. Valves are usually made of cast iron or brass. A domestic tap is commonly used to collect or tap water at desired points in the pipelines. Taps are made of brass, steel or plastic.

Flow Control Angle Valve

Flow control angle valve is used along with the applications to regulate the flow of water. The outlet of the valve and the control knob are at 90 degrees which is convenient to operate it.

Hacksaw

A hacksaw is used to cut pipes. It has a frame where the blade is tightened by means of a wing nut. Screw Drivers Screw drivers are used to tighten screws in the appliances. Screw drivers of various sizes are used.

Hammers

Ball peen hammer is commonly used in plumbing work where greater power is required in striking. Measuring Tape A measuring tape is used to measure the length of the pipe and also to mark the locations of the fittings, valves and appliances.

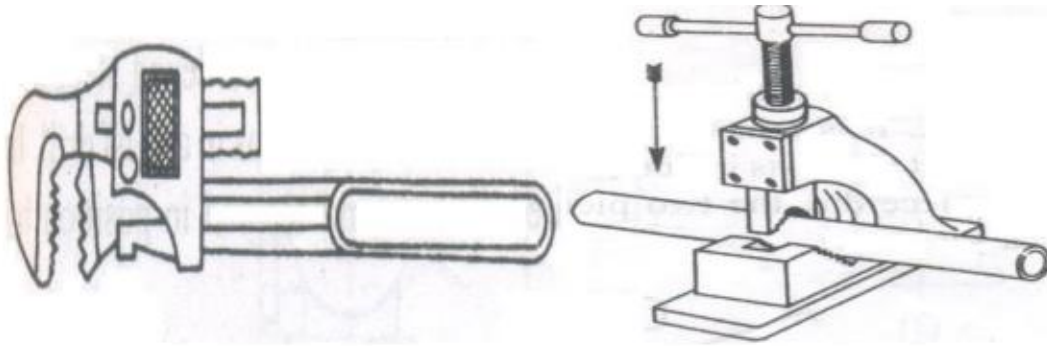

PIPE WRENCH

PIPEVICE

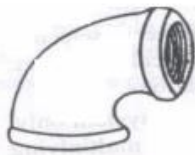

a - Elbow



b - Reducer coupling



c - Tee



g - Cap



h - Plug

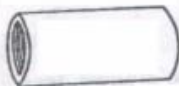

d - Coupling



e - Union



f - Bushing



i - Flange



j - Nipple

PIPE FITTINGS

EXPERIMENT 7

SMITHY SECTION

INTRODUCTION

Blacksmithy or hand forging is an ancient trade. It consists of heating a metal stock till it acquires sufficient plasticity, followed by hand forging involving hammering bending pressing etc., till the desired shape is attained.

Hand forging is the term used when the process is carried out by hand tools. If power operated machines are used for the process, it is known as machine forging. Hooks, links, lifting tackles and agricultural implements are some of the items that are produced by machine forging.

The following are the advantages of forging:

1. Strength and toughness is high.
2. Strength to weight ratio is high.
3. Internal defects are eliminated.
4. Forged parts need less or no machining.

FORGING OPERATIONS

DRAWING-DOWN: Drawing is the process of stretching the stock while reducing its cross-section locally. Forging the tapered end of a cold chisel is an example of drawing operation.

UPSETTING: It is a process of increasing the area of cross-section of a metal piece, with corresponding reduction in length. In this, only the portion to be upset is heated to forging temperature and the work is then struck at the end with a hammer.

FULLERING: Fullers are used for necking down a piece of work. Fullers are made of high carbon steel in two parts, called the top and bottom fullers.

FLATTENING: Flatters are the tools that are made with a perfectly flat face. These are used for finishing flat surfaces. A flatter of small size is known as sethammer and is used for finishing near corners and in confined spaces.

SWAGING: Swages, like fullers are also made of high carbon steel and are made in two parts called the top and bottom swages. These are used to reduce and finish to round, square or hexagonal forms.

BENDING: Bending of bars, flats, etc., is done to produce different types of bent shapes such as angles, ovals, circles, etc. Sharp bends as well as round bends may be made on the anvil.

TWISTING: It is also one form of bending. Sometimes, it is done to increase the rigidity of the work piece. Small pieces may be twisted by heating and clamping a pair of tongs on each end of the section to be twisted and applying a turning moment.

CUTTING (HOT AND COLD CHISELS): Chisels are used to cut metals, either in hot or cold state. The cold chisel is similar to fitter's chisel, except that it is longer and has a handle. A hot chisel is used for cutting hot metals and its cutting edge is long and slender. Chisels are made of tool steel, hardened and tempered.

MODEL NO.1

SQUARE PRISM

AIM

To make a square prism using the given cylindrical M.S rod.

MATERIALS REQUIRED:

Cylindrical M.S rod of dia 25 mm and length 100 mm, and coke for heating.

TOOLS REQUIRED:

- 1- Hammer
- 2- Tongs
- 3- Flattener
- 4- Anvil
- 5- Forge
- 6- Brass rule

LIST OF OPERATIONS:

- 1- Heating,
- 2- Hammering to square prism,
- 3- Jumping to reduce length .

PROCEDURE:

- 1- Copy the given drawing.
- 2- Collected the tools and material for the model.
- 3- Heat the given work piece in the hearth to red hot temperature.
- 4- Take the work piece from the hearth and keep it on the anvil in lengthwise and then hammer.
- 5- Turned the work piece to 90 degree after flattening the opposite sides and continued the heating & hammering to get exact shape of square prism.

- 6- To reduce the length of the prism to 122 mm, the jumping operation is performed by keeping the square prism on the anvil in the vertical position.
- 7- Finally flattened the four faces of the prism using the flattener and finished the square prism .
- 8- 8- Then checked the dimensions using steel rule.

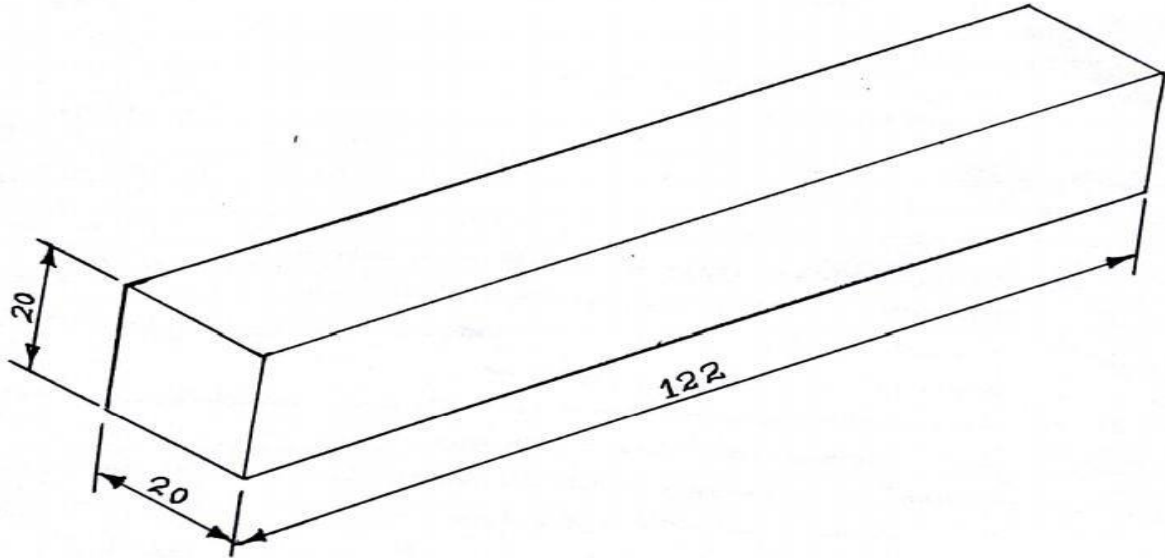

RESULT

INFERENCE

EXPERIMENT 8

WELDING

Welding is the process of joining similar or dissimilar metals by the application of heat, with or without application of pressure or filler metal. In such a way that the joint is equivalent in composition and characteristics of the metals joined. In the beginning welding was mainly used for repairing all kinds of worn or damaged parts. Now, it is extensively used in manufacturing industry, construction industry (construction of ships, tanks, locomotives and automobiles) and maintenance work, replacing riveting and bolting to a greater extent.

THE VARIOUS WELDING PROCESSES ARE:-

- i. Electric arc welding,
- ii. Gas welding
- iii. Thermit welding
- iv. Resistance welding,
- v. Friction welding.

ARC WELDING: In arc welding, the heat required for joining the metals is obtained from an electric arc. Transformers or motor generator sets are used as arc welding machines. These machines supply high electric currents at low voltages and an electrode is used to produce the necessary arc. The electrode serves as the filler rod and the arc melts the surfaces so that, the metals to be joined are actually fused together.

To supply the current for welding, three types of power sources are available: Transformers, motor generators and rectifiers. Sizes of welding machines are rated according to their approximate amperage capacity at 60% duty cycle, such as 160,200,260,300,400,600 and 600 amperes. This amperage is the rated current output at the working terminal.

EQUIPMENTS AND TOOLS

TRANSFORMERS: The transformer type of welding machine produces A.C current and is considered to be the least expensive. It takes power directly from a power supply line and transforms it to the voltage required for welding. Transformers are available in single phase and three phase in the market.

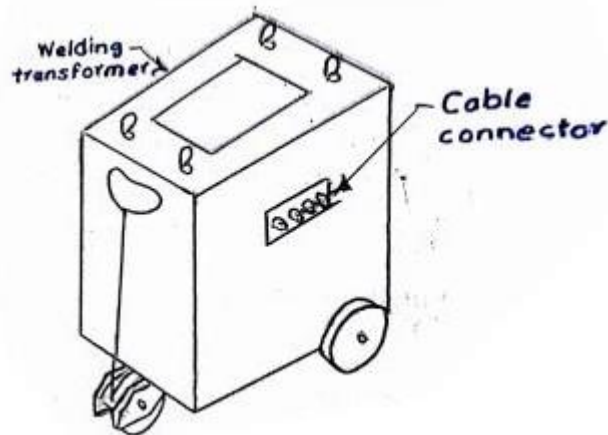

MOTOR GENERATORS: These are D.C generator «ets, in which electric motor and alternator are mounted on the same shaft to produce D.C power as per the requirement for welding. These are designed to produce D.C current in either straight or reversed polarity. The polarity selected for welding depends upon the kind of electrode used and the material to be welded.

WELDING CABLES: Two welding cables are required, one from the machine to the electrode holder and the other, from the machine to the ground clamp. Flexible cables are usually preferred because of the ease of using and coiling the cables. Cables are specified by their current carrying, capacity, say 300 A, 400 A, etc.

ELECTRODES: Filler rods used in arc welding are called electrodes. These are made of metallic wire called core wire, having approximately the same composition as the metal to be welded. These are coated uniformly with a protective coating called flux. Flux acts as an insulator of electricity. The size of an electrode is measured and designated by the diameter of the core wire in SWG and length, apart from the brand and code names; indicating the purpose for which they are most suitable

ELECTRODE HOLDER: The electrode holder is connected to the end of the welding cable and holds the electrode. It should be light, strong and easy to handle and should not become hot while in operation. The jaws of the holder are insulated, offering protection from electric shock.

GROUND CLAMP: It is connected to the end of the ground cable and is clamped to the work or welding table to complete the electric circuit . It should be strong and durable and give a low resistance connection.

WIRE BRUSH AND CHIPPING HAMMER: A wire brush is used for cleaning and preparing the work for welding. A chipping hammer is used for removing slag formation on welds.

FACE SHIELD: A face shield is used to protect the eyes and face from the rays of the arc and from spatter or flying particles of hot metal. It is available either in hand or helmet type. The hand type is convenient to use wherever the work can be done with one hand. The helmet type is more comfortable to wear and both hands free for the work.



WELDED JOINTS

Some common types of welded joints. Wherever possible, it is better to weld, by placing the parts in the flat position. In this, welding is done on top, so that gravity helps pull the molten metal into the joint.

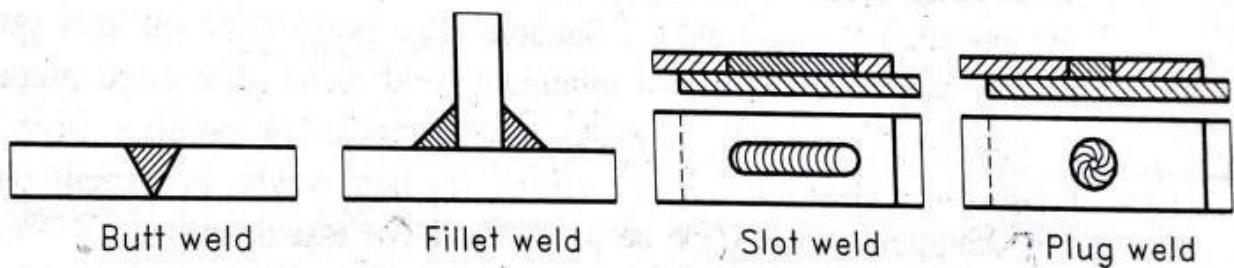

MODEL NO:1
STRAIGHT BEADS

AIM: -

To practice straight beads on the given mild steel flat piece in down hand position by arc welding.

MATERIALS REQUIRED:-

Work piece:-Mild steel flat of size 123 x 30 x 6mm – 1 no.

Electrode: - Mild steel electrode 10SWG (3.2mm) - 1no.

TOOLS REQUIRED:-

Steel rule, Try square ,Scriber, Hacksaw ,Bench vice ,Flat file ,face shield ,Tongs, Wire-brush, Chipping hammer, Welding machine and all other arc welding accessories.

LIST OF OPERATIONS:-

Measuring, Marking, Fixing, Cutting, Filing, Welding, Deslagging, Cleaning and Inspecting.

PROCEDURE

1. Copy the given drawing in the work record.
2. Cut the work piece as per the drawing.
3. File the work piece to the dimensional accuracy.
4. Kept the work piece on the welding table in the down hand position.
5. Set the ampere of the machine and use protective cloth , select suitable electrode and proper shield.
6. Remove the slag and spatters using the chipping hammer and wire brush.
7. After completion of weld , the weld bead should be inspected.

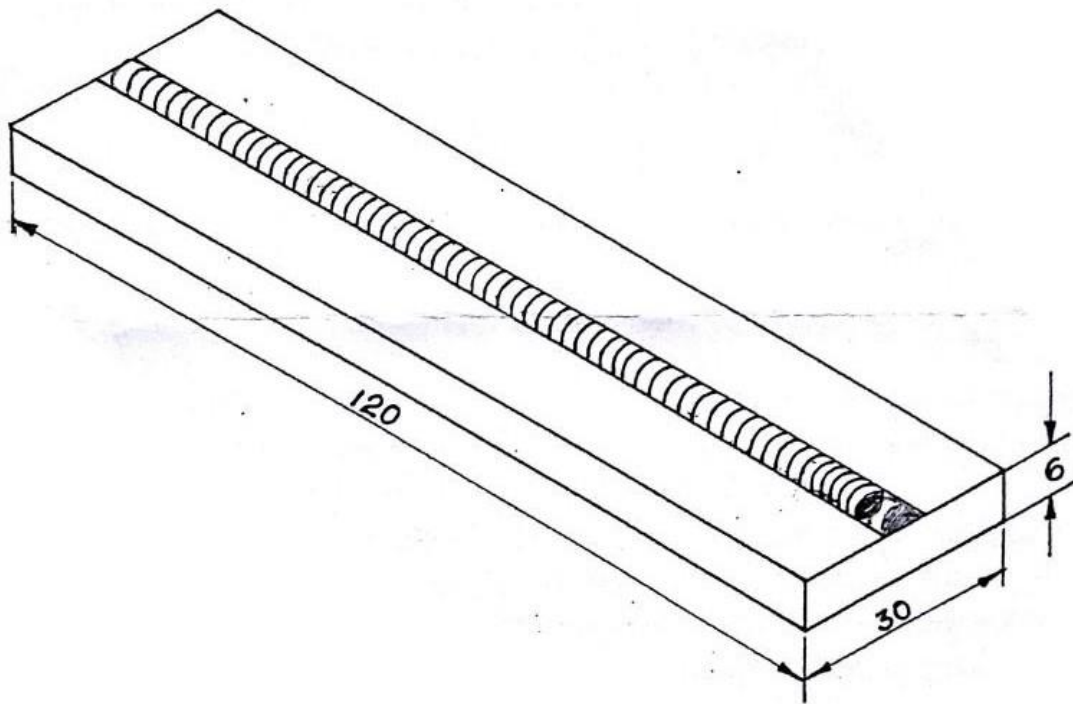

SCALE 1:1 All dimensions are in mm

RESULT

INFERENCE

MODEL NO 2

BUTT JOINT

AIM: -

To make a butt joint on the given mild steel flat pieces in down hand position by arc welding.

MATERIALS REQUIRED:-

Work piece:-Mild steel flat of size 123 x 30 x 6mm – 2 nos.

Electrode: - Mild steel electrode 10SWG (3.2mm) - 1no.

TOOLS REQUIRED:-

Steel rule, Try square ,Scriber, Hacksaw ,Bench vice ,Flat file ,face shield ,Tongs, Wire-brush, Chipping hammer, Welding machine and all other arc welding accessories.

LIST OF OPERATIONS:-

Measuring, Marking, Fixing, Cutting, Filing, Welding, Deslagging, Cleaning and Inspecting.

PROCEDURE

1. Copy the given drawing in the work record.
2. Cut the work piece as per the drawing.
3. File the work piece to the dimensional accuracy.
4. Kept the work piece on the welding table in the down hand position.
5. Set the ampere of the machine and use protective cloth , select suitable electrode and proper shield.
6. Tack weld the two ends of the work piece and check the alignment.
7. Remove the slag and spatters using the chipping hammer and wire brush.
8. After completion of weld , the weld bead should be inspected.

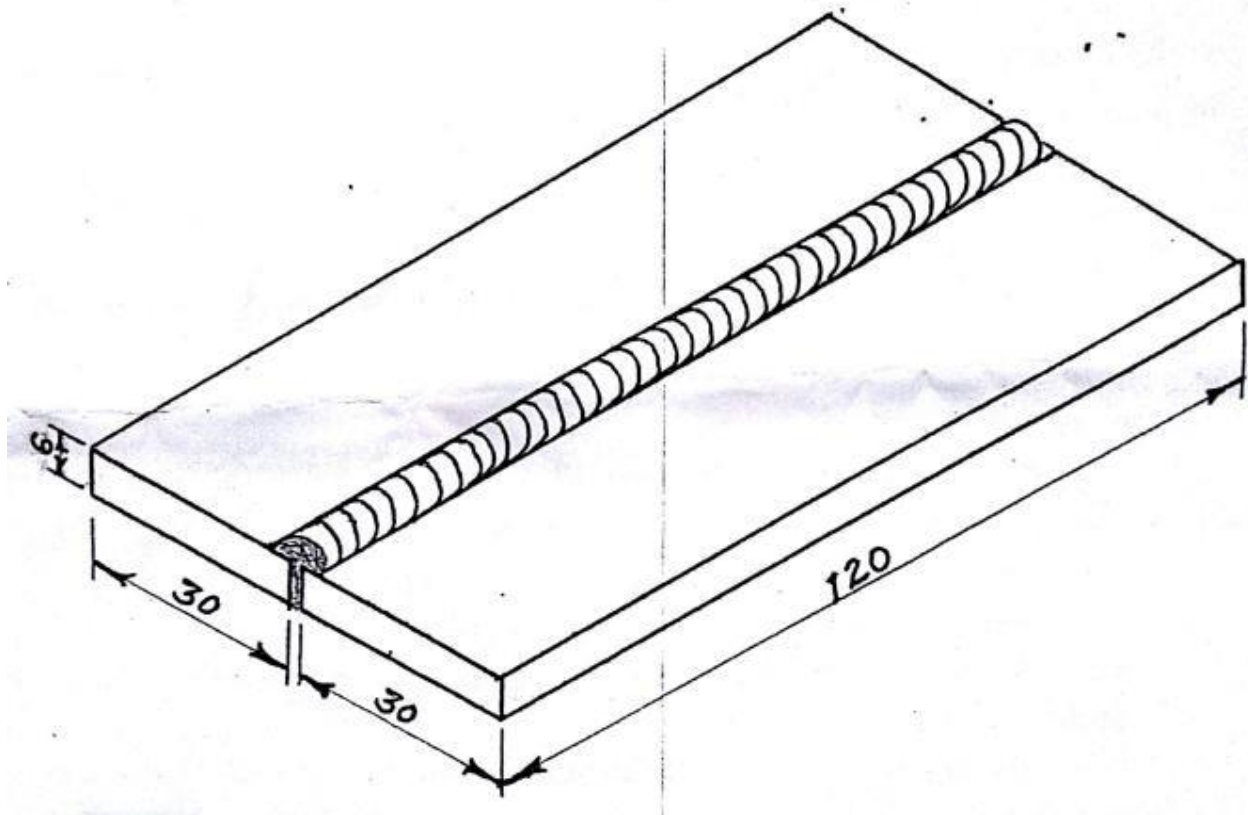

SCALE 1:1, All dimensions are in mm

RESULT

INFERENCE

MODEL NO: 3

FILLET (TEE) JOINT

AIM: -

To make a butt joint on the given mild steel flat pieces in down hand position by arc welding.

MATERIALS REQUIRED:-

Work piece:-Mild steel flat of size 123 x 30 x 6mm – 2 nos.

Electrode: - Mild steel electrode 10SWG (3.2mm) - 1no.

TOOLS REQUIRED:-

Steel rule, Try square ,Scriber, Hacksaw ,Bench vice ,Flat file ,face shield ,Tongs, Wire-brush, Chipping hammer, Welding machine and all other arc welding accessories.

LIST OF OPERATIONS:-

Measuring, Marking, Fixing, Cutting, Filing, Welding, Deslagging, Cleaning and Inspecting.

PROCEDURE

1. Copy the given drawing in the work record.
2. Cut the work piece as per the drawing.
3. File the work piece to the dimensional accuracy.
4. Kept the work piece on the welding table in the down hand position.
5. Set the ampere of the machine and use protective cloth, select suitable electrode and proper shield.
6. Tack welds the two ends of the work piece and checks the alignment.

7. Remove the slag and spatters using the chipping hammer and wire brush.
8. After completion of weld, the weld bead should be inspected.

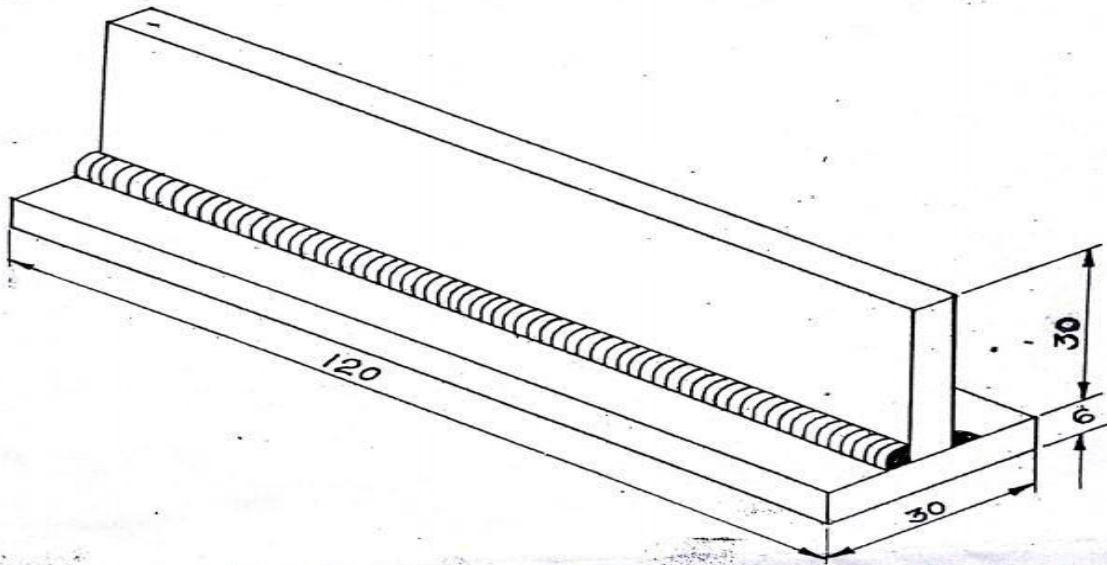

SCALE: 1:1, All dimensions are in mm

RESULT

INFERENCE

EXPERIMENT NO 9

MECHANICAL TOOLS

DRILLING MACHINE

Drilling machine is one of the most important machine tools in a workshop. It was designed to produce a cylindrical hole of required diameter and depth on metal workpieces. Though holes can be made by different machine tools in a shop, drilling machine is designed specifically to perform the operation of drilling and similar operations.

Drilling can be done easily at a low cost in a shorter period of time in a drilling machine. Drilling can be called as the operation of producing a cylindrical hole of required diameter and depth by removing metal by the rotating edges of a drill.

The cutting tool known as drill is fitted into the spindle of the drilling machine. A mark of indentation is made at the required location with a center punch. The rotating drill is pressed at the location and is fed into the work. The hole can be made upto a required depth.

Construction of a drilling machine

The basic parts of a drilling machine are a base, column, drillhead and spindle. The base made of cast iron may rest on a bench, pedestal or floor depending upon the design. Larger and heavy duty machines are grounded on the floor.

The column is mounted vertically upon the base. It is accurately machined and the table can be moved up and down on it.

The drill spindle, an electric motor and the mechanism meant for driving the spindle at different speeds are mounted on the top of the column. Power is transmitted from the electric motor to the spindle through a flat belt or a 'V' belt

Types of drilling machines

Drilling machines are manufactured in different types and sizes according to the type of operation, amount of feed, depth of cut, spindle speeds, method of spindle movement and the required accuracy

The different types of drilling machines are:

1. Portable drilling machine (or) Hand drilling machine
2. Sensitive drilling machine (or) Bench drilling machine
3. Upright drilling machine
4. Radial drilling machine

5. Gang drilling machine
6. Multiple spindle drilling machine
7. Deep hole drilling machine

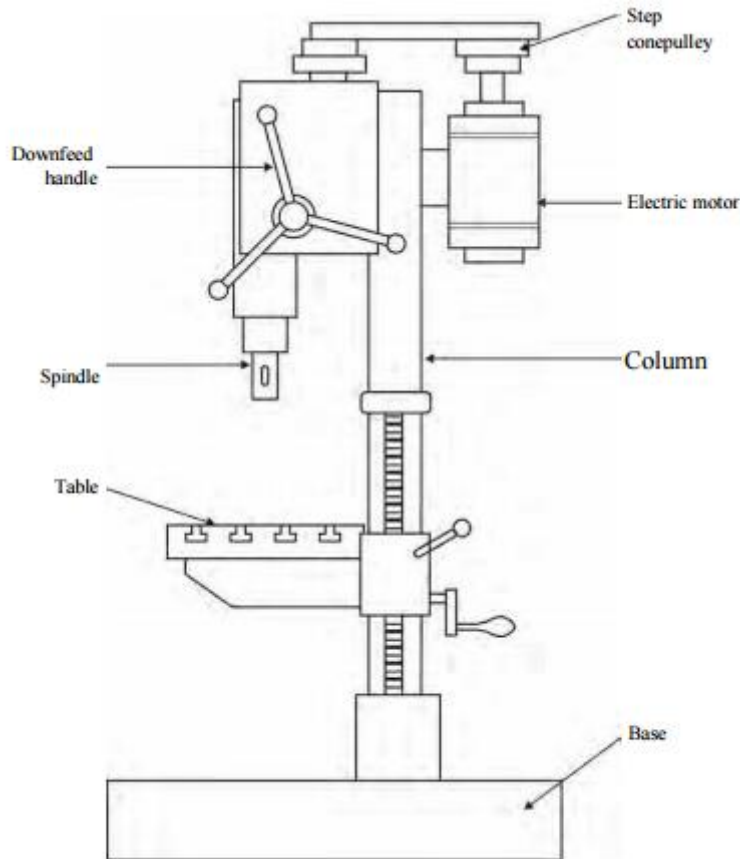

DRILLING MACHINE

BASE

Base is made of cast iron as it can withstand vibrations set by the cutting action. It is erected on the floor of the shop by means of bolts and nuts. It is the supporting member as it supports column and other parts on it. The top of the base is accurately machined and has 'T'- slots. When large workpieces are to be held, they are directly mounted on the base.

COLUMN

Column stands vertically on the base and supports the work table and all driving mechanisms. It is designed to withstand the vibrations set up due to the cutting action at high speeds.

TABLE

Table is mounted on the column and can be adjusted up and down on it. It is provided with 'T'-slots for workpieces to be mounted directly on it. Table may have the following adjustments Vertical adjustment obtained by the rack on the column and a pinion in the table Circular adjustment about its own axis After the required adjustments are made, the table is clamped in position.

DRILL HEAD

The drillhead is mounted on the top of the column. It houses the driving and feeding mechanism of the spindle. The spindle can be provided with hand or power feed . There are separate hand wheels for quick hand feed and sensitive hand feed. The handle is spring loaded so that the drill spindle is released from the work when the operation is over.

MILLING MACHINE

Milling is a process of removing metal by feeding the work against a rotating multipoint cutter. The machine tool intended for this purpose is known as milling machine.

It is found in shops where tools and cutters are manufactured. The surface obtained by this machine tool is superior in quality and more accurate and precise.

Eli Whitney designed a complete milling machine in 1818. In the year 1861 Joseph Brown, a member of Brown and Sharp company developed the first universal milling machine.

Column and knee type milling machine

Base

It is made of cast iron and supports all the other parts of the machine tool. A vertical column is mounted upon the base. In some machines, the base serves as a reservoir for cutting fluid.

Column

It is mounted upon the base and is box shaped. It houses the mechanism for providing drive for the spindle. The front vertical face of the column is machined accurately to form dovetail guideways for the knee to move up and down. The top of the column holds an overhanging arm.

Knee

It slides up and down on the guideways of the column. An elevating screw mounted on the base obtains this movement. Saddle is mounted upon the knee and moves in a cross direction

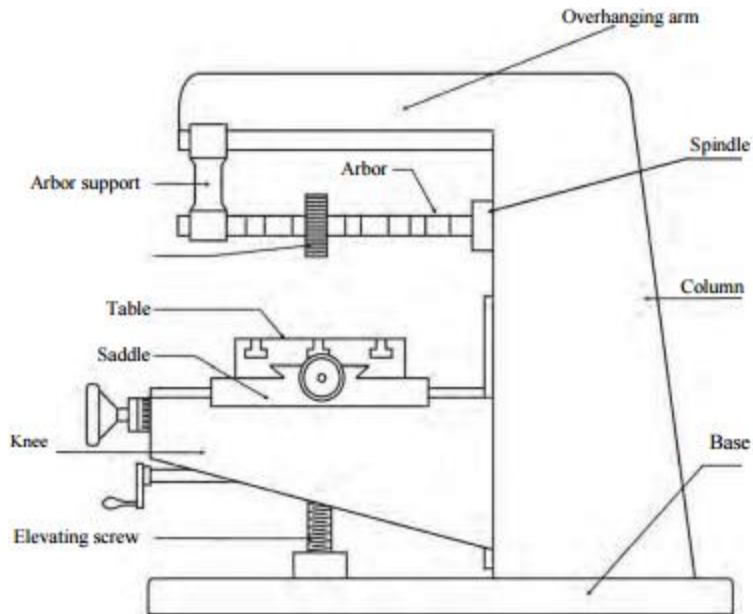

Saddle

It is mounted on the guideways of the knee and moves towards or away from the face of the column. This movement can be obtained either by power or by hand. The top of the saddle has guideways for the table movement.

Table

The table is moved longitudinally either by power or manually on the guideways of the saddle. The trip dogs placed on it control the movement of the table. The table of a universal milling machine can be swiveled horizontally to perform helical works. The top surface of the table has got 'T' – slots on which the workpieces or other work holding devices are mounted.

Spindle

It is located in the upper part of the column. It receives power from the motor through belt, gears and clutches. The front end of the spindle has got a taper hole into which the cutters are held with different cutter holding devices.

Vertical milling machine

It is very similar to a horizontal milling machine in construction as it has the same parts of base, column, knee, saddle and table. The spindle of the machine is positioned vertically. The cutters are mounted on the spindle. The spindle is rotated by the power obtained from the mechanism placed inside the column. Angular surfaces are machined by swiveling the spindle head

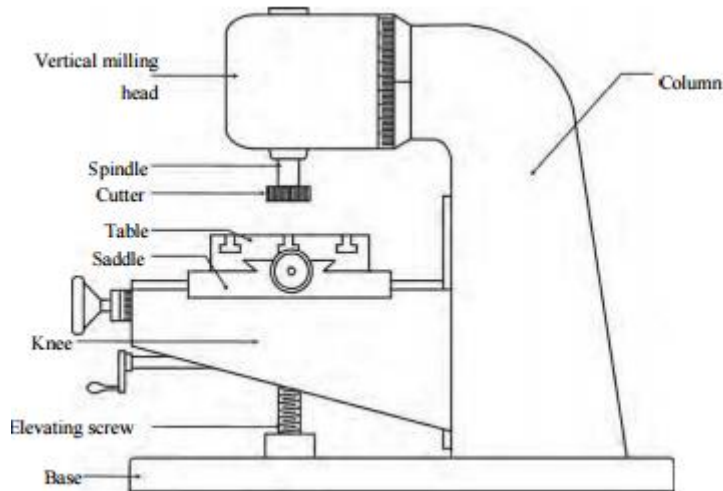

GRINDING MACHINE

Grinding is a metal cutting operation like any other process of machining removing metal in comparatively smaller volume. The cutting tool used is an abrasive wheel having many numbers of cutting edges. The machine on which grinding the operation is performed is called a grinding machine.

Grinding is done to obtain very high dimensional accuracy and better appearance. The accuracy of grinding process is 0.000025mm . The amount of material removed from the work is very less. 4.2

Types of grinding machines

According to the accuracy of the work to be done on a grinding machine, they are classified as

1. Rough grinding machines
2. Precision grinding machines

Rough grinding machines - The rough grinding machines are used to remove stock with no reference to the accuracy of results. Excess metal present on the cast parts and welded joints are removed by rough grinders.

The main types of rough grinders are

1. Hand grinding machine
2. Bench grinding machine
3. Floor stand grinding machine
4. Flexible shaft grinding machine
5. Swing frame grinding machine
6. Abrasive belt grinding machine

Surface grinding machines

Surface grinding machines are employed to finish plain or flat surfaces horizontally, vertically or at any angle.

There are four different types of surface grinders. They are

1. Horizontal spindle and reciprocating table type
2. Horizontal spindle and rotary table type
3. Vertical spindle and reciprocating table type
4. Vertical spindle and rotary table type

Horizontal spindle surface grinding machine - The majority of surface grinders are of horizontal spindle type. In the horizontal type of the machine, grinding is performed by the abrasives on the periphery of the wheel. Though the area of contact between the wheel and the work is small, the speed is uniform over the grinding surface and the surface finish is good. The grinding wheel is mounted on a horizontal spindle and the table is reciprocated to perform grinding operation

Base

The base is made of cast iron. It is a box like casting which houses all the table drive mechanisms. The column is mounted at the back of the base which has guideways for the vertical adjustment of the wheelhead.

Saddle

Saddle is mounted on the guideways provided on the top of the base. It can be moved at cross towards or away from the column.

Table

The table is fitted to the carefully machined guideways of the saddle. It reciprocates along the guideways to provide the longitudinal feed. The table is provided with 'T'-

slots for clamping workpieces directly on the table or for clamping grinding fixtures or magnetic chuck.

Wheelhead

An electric motor is fitted on the wheelhead to drive the grinding wheel. The wheelhead is mounted on the guideways of the column, which is secured to the base. It can be raised or lowered with the grinding wheel to accommodate workpieces of different heights and to set the wheel for depth of cut

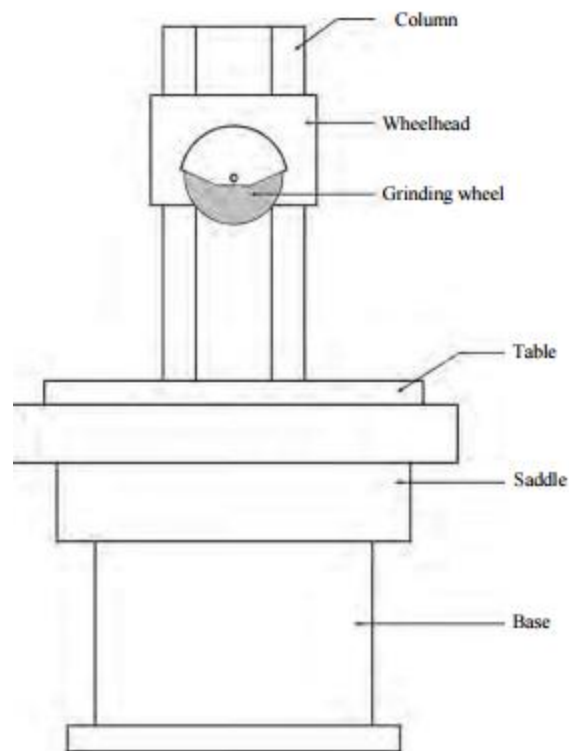

LATHE

Lathe machine: The lathe machine is one of the oldest machine tools and came from the early tree lathe which was a device for rotating and machining a piece of wood between two adjacent trees. A rope would be wound around the work with one end attached to a flexible branch of a tree and the other end pulled by a man to rotate the job. Hand tools are used on it.

Function of lathe machine: The main function of a lathe machine is to remove metal from a piece of work to give it the required shape and size. The work is held securely and rigidly on the machine and then turned against the cutting tools which remove metal from the work in the form of chips.

Tail stock

The tail stock the bed and it is in any position to act. It has two uses: 1. Supports the centres. 2. To hold a tool tapping etc

CARRIAGE: In between the ways on the bed ways to it either long, it is located at on the inner ways at the right hand is a non-rotating part which slides and can be clamped to accommodate different lengths of work pieces.

SHAPER

Shaper:- The shaper is a reciprocating type of machine tool intended to produce flat surfaces. The surface may be horizontal, vertical or inclined

Working principle:- The job is fixed rigidly in a suitable vice or directly clamped on the machine table. The tool is held in the tool post mounted on the ram of the machine. This ram reciprocates to and fro, and in doing so, makes the tool to cut the material in the forward stroke. No cutting takes place during the return stroke of the ram. It is called idle stroke. The job is given an intended feed, in a direction normal to the line of action of the cutting tool.

Types of shapers:-

1. According to the type of mechanism used for giving reciprocating motion to the ram.

- a. Crank type
- b. Geared type
- c. Hydraulic type

2. According to the position and travel of ram .

- a. Horizontal type
- b. Vertical type
- c. Travelling head type

3. According to the type of design of the table

- a. Standard shaper
- b. Universal shaper

4. According to the type of cutting stroke
 - a. Push type
 - b. Draw type

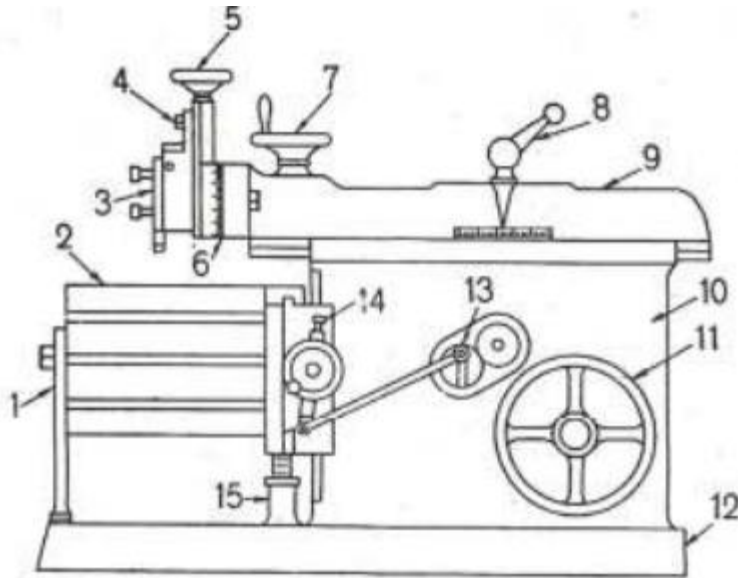

1. Table support, 2. Table, 3. Clapper box, 4. Apron clamping bolts, 5. Downfeed hand wheel, 6. Swivel base degree graduations, 7. Position of stroke adjustment handwheel, 8. Ram block locking handle, 9. Ram, 10. Column, 11. Driving pulley, 12. Base, 13. Feed disc, 14. Pawl mechanism, 15. Elevating screw.

The metal is removed in the forward cutting stroke, while the return stroke no metal is removed during this period. To reduce the total machining time it is necessary to reduce time taken by the return stroke. The shaper mechanism should be so designed that it can allow the ram holding the tool to move at comparatively slower speed during the forward cutting stroke and during the return stroke the ram move faster rate to reduce the idle return time. The mechanism is called quick return mechanism.

1. Crank and slotted mechanism
2. Whitworth quick return mechanism
3. Hydraulic shaper mechanism

EXPERIMENT 10

STUDY OF COMPUTER NUMERICAL CONTROL MACHINES

Computer Numerical Control (CNC) Machines With the availability of microprocessors in mid 70's the controller technology has made tremendous progress. The new control systems are termed as computer numerical control(CNC) which are characterized by the availability of a dedicated computer and enhanced memory in the controller. These may also be termed "soft wired numerical control".

A CNC system basically consists of the following:

- (a) Central processing unit (CPU)
- (b) Servo control unit
- (c) Operator control panel
- (d) Machine control panel
- (e) Programmable logic controller
- (f) Other peripheral devices.

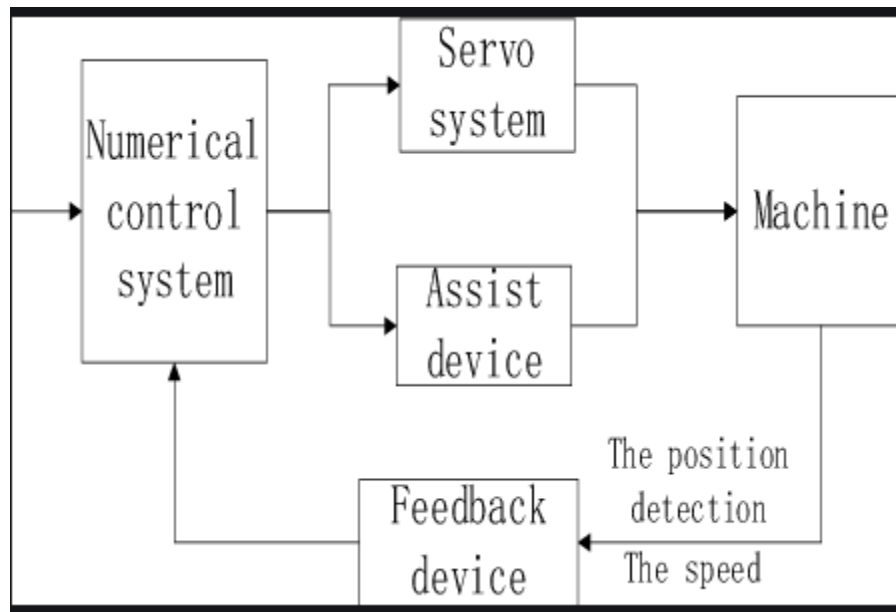

Functions of CNC

1. Storage of more than one partprogram: With improvements in computer storage technology, newer CNC controllers have sufficient capacity to store

multiple programs. Controller manufacturers generally offer one or more memory expansion options to the MCU

2. Various forms of program input: Whereas conventional (hard-wired) MCUs are limited to punched tape as the input medium for entering part programs, CNC controllers generally possess multiple data entry capabilities, such as punched tape, magnetic tape, floppy diskettes, RS-232 communications with external computers, and manual data input (operator entry of program).

3. Program editing at the machine tool: CNC permits a part program to be edited while it resides in the MCU computer memory. Hence, a part program can be tested and corrected entirely at the machine site, rather than being returned to the programming office for corrections. In addition to part program corrections, editing also permits cutting conditions in the machining cycle to be optimized. After the program has been corrected and optimized, the revised version can be stored on punched tape or other media for future use.

CNC machining is a manufacturing process suitable for a wide variety of industries, including automotive, aerospace, construction, and agriculture, and able to produce a range of products, such as automobile frames, surgical equipment, airplane engines, gears, and hand and garden tools. The process encompasses several different computer-controlled machining operations—including mechanical, chemical, electrical, and thermal processes—which remove the necessary material from the workpiece to produce a custom-designed part or product. While chemical, electrical, and thermal machining processes are covered in a later section, this section explores some of the most common mechanical CNC machining operations including:

- Drilling
- Milling
- Turning

CNC Drilling

Drilling is a machining process which employs multi-point drill bits to produce cylindrical holes in the workpiece. In CNC drilling, typically the CNC machine feeds the rotating drill bit perpendicularly to the plane of the workpiece's surface, which produces vertically-aligned holes with diameters equal to the diameter of the drill bit employed for the drilling operation. However, angular drilling operations can also be performed through the use of specialized machine configurations and workholding devices. Operational capabilities of the drilling process include counterboring, countersinking, reaming, and tapping.

CNC Milling

Milling is a machining process which employs rotating multi-point cutting tools to remove material from the workpiece. In CNC milling, the CNC machine typically feeds the workpiece to the cutting tool in the same direction as the cutting tool's rotation, whereas in manual milling the machine feeds the workpiece in the opposite direction to the cutting tool's rotation. Operational capabilities of the milling process include face milling—cutting shallow, flat surfaces and flat-bottomed cavities into the workpiece—and peripheral milling—cutting deep cavities, such as slots and threads, into the workpiece.

CNC Turning

Turning is a machining process which employs single-point cutting tools to remove material from the rotating workpiece. In CNC turning, the machine—typically a CNC lathe machine—feeds the cutting tool in a linear motion along the surface of the rotating workpiece, removing material around the circumference until the desired diameter is achieved, to produce cylindrical parts with external and internal features, such as slots, tapers, and threads. Operational capabilities of the turning process include boring, facing, grooving, and thread cutting. When it comes down to a CNC mill vs. lathe, milling, with its rotating cutting tools, works better for more complex parts. However, lathes, with rotating workpieces and stationary cutting tools, work best for faster, more accurate creation of round parts.